

RAILIFT® SERIES

The RCM Series



RCM SPECIFICATIONS

Designed for delivery systems requiring Medium Duty lifting capacities. No other liftgate offers the high performance and low maintenance of the RCM. Popular applications include full size and narrow van bodies, cutaways, step vans, platform and stake bodies. Also available are the above bed travel, AB Models for dock delivery from vehicles with bed heights lower than dock height.

- Platform lowers below bed for dock loading or access to light parcels
- Optional 10" Aluminum Retention Ramp is ideal for handling wheeled carts.
- Self lubricating hinges allows easy adjustment from stored, retention, and ramp positions
- Includes Maxon's patented automatic ramp latch for simplified operation.
- Level ride, low profile platforms are standard with 6" fixed ramp
- All RCMs use forklift chain for strong long lasting performance.

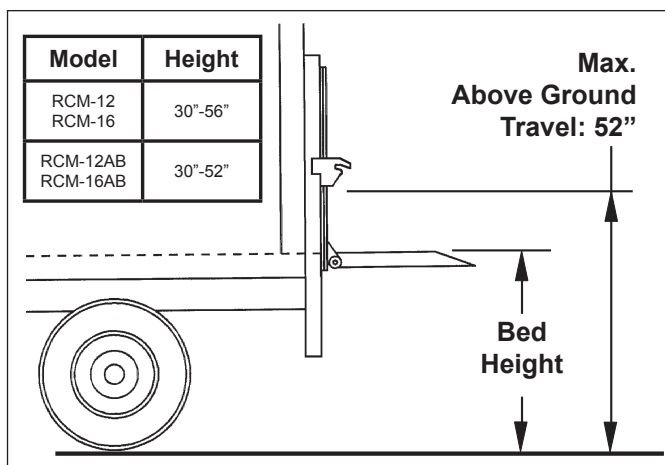

Mounting Requirement Dimensions

MODEL CAPACITY	BODY WIDTH	RAMP	BED HEIGHT
RCM-12 1,250 LBS.	86"	30" x 80" 30" x 85" 30" x 90"	6" Fixed (Standard for all RCM Models)
RCM-12AB (Above Bed Travel)		30" x 80" 36" x 80" 30" x 85" 36" x 85" 30" x 90" 36" x 90"	
RCM-16 (1,600 LBS.)	96"		10" Aluminum Re- tention Ramp (Optional on 36" Platforms)
RCM-16AB (Above Bed Travel)			

RAILIFT[®] SERIES

The RCM Series

MAXON[®]

Standard Equipment

- Plastic Pump and Motor Enclosure
- Marine Style Electric Switch Controls
- Above Bed Travel (On "AB" Models)
- 4 Steps Paint Process

Must Select Options

- *Auxiliary Hand Pump
 - *150 Amp Circuit Breaker (No Charge Option)
 - Hand Held Control
- *Preferred Options



EASY CLOSING PLATFORM

Platform closing is assisted by powerful adjustable double torsion bars, designed to reduce the force required to close the platform to 15 Lbs. or less.



SIMPLE, AUTOMATIC CONTROLS

Maxon's Electric Switch Control Station is mounted on the curbside liftgate column making it easily accessible from the ground or while riding on the platform. The Automatic Safety Latch engages to keep platform in stowed position in the event of hydraulic failure. Requires no driver effort.



ABOVE BED PLATFORM LEVEL

The RCM-AB models allow the platforms to rise above bed height when installed on low bed vehicles. This provides access to docks up to 52" high.

FORKLIFT TYPE LEAF CHAIN

The RCM uses forklift technology in its use of leaf chain to lift our loads.

Distributed by: