

M-90-3
REV. K
AUGUST 2010

MAXON[®]

MAINTENANCE MANUAL

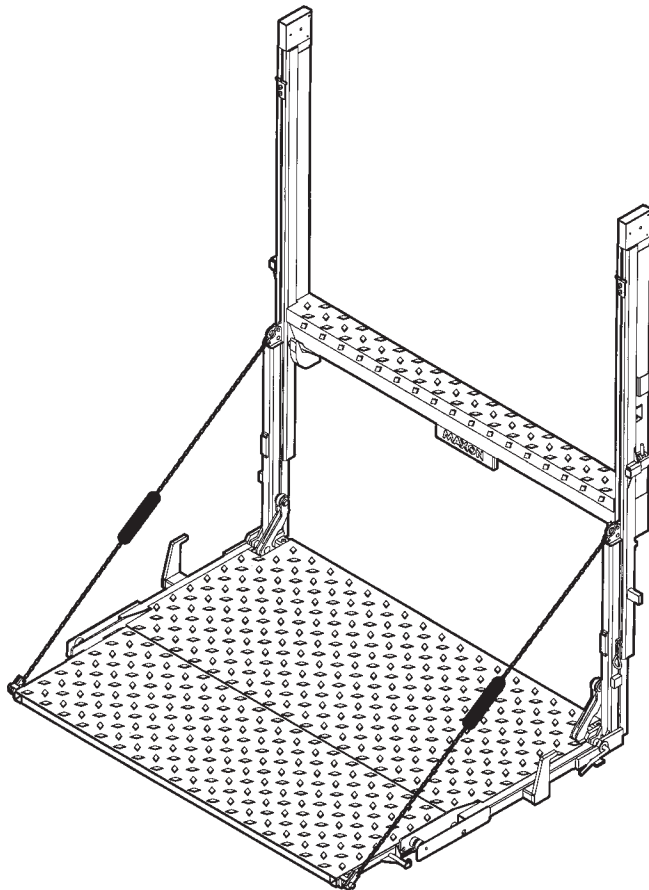

RC-2B

RC-3B

RC-4B

RC-5B

RC-6B

RC-6K

MAXON[®]

11921 Slauson Avenue.
Santa Fe Springs, CA. 90670
(800) 227-4116

MAXON[®]

LIFT CORP.

11921 Slauson Ave.
Santa Fe Springs, CA. 90670

CUSTOMER SERVICE:

TELEPHONE (562) 464-0099 TOLL FREE (800) 227-4116

FAX: (888) 771-7713

NOTE: For latest version of all Manuals (and replacements), download the
Manuals from Maxon's website at www.maxonlift.com.

WARRANTY/ RMA POLICY & PROCEDURE

LIFTGATE WARRANTY

Type of Warranty: Full Parts and Labor
Term of Warranty: Standard Liftgates - 2 years from ship date or 6,000 cycles
Premium Liftgates - 2 years from ship date or 10,000 cycles

This warranty shall not apply unless the product is installed, operated and maintained in accordance with MAXON Lift's specifications as set forth in MAXON Lift's Installation, Operation and Maintenance manuals. This warranty does not cover normal wear, maintenance or adjustments, damage or malfunction caused by improper handling, installation, abuse, misuse, negligence, or carelessness of operation. In addition, this warranty does not cover equipment that has had unauthorized modifications or alterations made to the product.

MAXON agrees to replace any components which are found to be defective during the first 2 years of service, and will reimburse for labor based on MAXON's Liftgate Warranty Flat Rate Schedule. (Copy of the Flat Rate is available at www.maxonlift.com.)

All warranty repairs must be performed by an authorized MAXON warranty facility. For any repairs that may exceed \$500, including parts and labor, MAXON's Technical Service Department must be notified and an "Authorization Number" obtained.

All claims for warranty must be received within 30 Days of the repair date, and include the following information:

1. Liftgate Model Number and Serial Number
2. The End User must be referenced on the claim
3. Detailed Description of Problem
4. Corrective Action Taken, and Date of Repair
5. Parts used for Repair, Including MAXON Part Number(s)
6. MAXON R.M.A. # and/or Authorization # if applicable (see below)
7. Person contacted at MAXON if applicable
8. Claim must show detailed information i.e. Labor rate and hours of work performed

Warranty claims can also be placed online at www.maxonlift.com. Online claims will be given priority processing.

All claims for warranty will be denied if paperwork has not been received or claim submitted via Maxon website for processing by MAXON's Warranty Department within 30 days of repair date.

All components may be subject to return for inspection, prior to the claim being processed. MAXON products may not be returned without prior written approval from MAXON's Technical Service Department. Returns must be accompanied by a copy of the original invoice or reference with original invoice number and are subject to a credit deduction to cover handling charges and any necessary reconditioning costs. **Unauthorized returns will be refused and will become the responsibility of the returnee.**

Any goods being returned to MAXON Lift must be pre-approved for return, and have the R.M.A. number written on the outside of the package in plain view, and returned freight prepaid. All returns are subject to a 15% handling charge if not accompanied by a detailed packing list. Returned parts are subject to no credit and returned back to the customer. Defective parts requested for return must be returned within 30 days of the claim date for consideration to:

MAXON Lift Corp.
10321 Greenleaf Ave., Santa Fe Springs, CA 90670
Attn: RMA# _____

MAXON's warranty policy does not include the reimbursement for travel time, towing, vehicle rental, service calls, oil, batteries or loss of income due to downtime. Fabrication or use of non Maxon parts, which are available from MAXON, are also not covered.

MAXON's Flat Rate Labor Schedule takes into consideration the time required for diagnosis of a problem.

All Liftgates returned are subject to inspection and a 15% restocking fee. Any returned Liftgates or components that have been installed or not returned in new condition will be subject to an additional reworking charge, which will be based upon the labor and material cost required to return the Liftgate or component to new condition.

PURCHASE PART WARRANTY

Term of Warranty: 1 Year from Date of Purchase.

Type of Warranty: Part replacement only. MAXON will guarantee all returned genuine MAXON replacement parts upon receipt and inspection of parts and original invoice.

All warranty replacements parts will be sent out via ground freight. If a rush shipment is requested, all freight charges will be billed to the requesting party.

TABLE OF CONTENTS

WARNINGS	6
SAFETY INSTRUCTIONS	6
PERIODIC MAINTENANCE	8
DECALS	8
QUARTERLY MAINTENANCE SCHEDULE	10
QUARTERLY MAINTENANCE CHECKLIST.....	11
CHECKING HYDRAULIC FLUID	12
CHANGING HYDRAULIC FLUID	14
REPLACING PARTS	15
REPLACING CYLINDER SEALS	15
CHECK VALVE	15
WIRE ROPE REMOVAL.....	16
WIRE ROPE REPLACEMENT	21
CYLINDER REPLACEMENT	28
RELEASING EMERGENCY BRAKE.....	29
PUMP-SHAFT, COUPLING AND FILTER	30
CHECKING SOLENOID SWITCH.....	30
FUSED POWER CABLE	31
WIRING TO PUMP MOTOR.....	32
PUMP WIRING FOR CAM TYPE CLOSER	33
PUMP WIRING FOR HYDRAULIC CLOSER.....	34
WIRE ROPE SCHEMATIC	35
WIRE ROPE MAINTENANCE	36
ADJUSTMENTS	37
WIRE ROPE ADJUSTMENT (NEW ROPES).....	37

WIRE ROPE ADJUSTMENT	39
CAM FOLLOWER ADJUSTMENT	41
PUMP PRESSURE SETTING ADJUSTMENT	42
3 POINT CHAIN INSPECTION	44
PARTS BREAKDOWN	46
MAIN ASSEMBLY-1	46
MAIN FRAME-COLUMN ASSEMBLY-1	48
MAIN FRAME-COLUMN ASSEMBLY-2	50
CAM FOLLOWER ASSEMBLY	52
RUNNER ASSEMBLY	54
EMERGENCY BRAKE	56
PUMP ASSEMBLY (CAM PLATFORM CLOSER).....	58
PUMP ASSEMBLY (HYDRAULIC PLATFORM CLOSER)	59
PUMP (CAM PLATFORM CLOSER).....	60
PUMP (HYDRAULIC PLATFORM CLOSER).....	62
PUMP BOX.....	64
PLATFORMS.....	65
FLIPOVERS	66
ONE-PIECE PLATFORMS (CAM TYPE CLOSER)	67
RC/RCT HYDRAULIC CLOSER COMPONENTS.....	68
TROUBLESHOOTING.....	70
CAM PLATFORM CLOSER	70

Comply with the following **WARNINGS** and **SAFETY INSTRUCTIONS** while maintaining Liftgates. See Operation Manual for operating safety requirements.

WARNING

- Do not stand, or allow obstructions, under the platform when lowering the Liftgate. **Be sure your feet are clear of the Liftgate.**
- **Keep fingers, hands, arms, legs, and feet clear of moving Liftgate parts (and platform edges) when operating the Liftgate.**
- **Correctly stow platform when not in use. Extended platforms could create a hazard for people and vehicles passing by.**
- **Disconnect Liftgate power cable from battery** before repairing or servicing Liftgate.
- If it is necessary to stand on the platform while maintaining the Liftgate, keep your feet and any objects clear of the inboard edge of the platform. Your feet or objects on the platform can become trapped between the platform and the Liftgate extension plate.
- Recommended practices for welding on steel parts are contained in the current **AWS (American Welding Society) D1.1 Structural Welding Code - Steel**. Damage to Liftgate and/or vehicle, and personal injury could result from welds that are done incorrectly.
- Recommended practices for welding on aluminum parts are contained in the current **AWS (American Welding Society) D2.1 Structural Welding Code - Aluminum**. Damage to Liftgate and/or vehicle, and personal injury could result from welds that are done incorrectly.

SAFETY INSTRUCTIONS

- Read and understand the instructions in this **Maintenance Manual** before performing maintenance on the Liftgate.
- Before operating the Liftgate, read and understand the operating instructions in **Operation Manual**.
- Comply with all **WARNING** and instruction decals attached to the Liftgate.
- Keep decals clean and legible. If decals are illegible or missing, replace them. Free replacement decals are available from **Maxon Customer Service**.
- Consider the safety and location of bystanders and location of nearby objects when operating the Liftgate. Stand to one side of the platform while operating the Liftgate
- Do not allow untrained persons to operate the Liftgate.
- Wear appropriate safety equipment such as protective eyeglasses, faceshield and clothing while performing maintenance on the Liftgate and handling the battery. Debris from drilling and contact with battery acid may injure unprotected eyes and skin.
- Be careful working by an automotive type battery. Make sure the work area is well ventilated and there are no flames or sparks near the battery. Never lay objects on the battery that can short the terminals together. If battery acid gets in your eyes, immediately seek first aid. If acid gets on your skin, immediately wash it off with soap and water.

MAXON[®]

11921 Slauson Ave. Santa Fe Springs, CA. 90670 (800) 227-4116 FAX (888) 771-7713

- If an emergency situation arises (vehicle or Liftgate) while operating the Liftgate, release the control switch to stop the Liftgate.
- A correctly installed Liftgate operates smoothly and reasonably quiet. The only noticeable noise during operation comes from the power unit while the platform is raised. Listen for scraping, grating and binding noises and correct the problem before continuing to operate Liftgate.
- Use only **Maxon Authorized Parts** for replacement parts. Provide Liftgate model and serial number information with your parts order. Order replacement parts from:

MAXON LIFT CORP. Customer Service
11921 Slauson Ave., Santa Fe Springs, CA 90670

Online: www.maxonlift.com

Express Parts Ordering: Phone (800) 227-4116 ext. 4345

Email: Ask your Customer Service representative

PERIODIC MAINTENANCE DECALS

MAXON[®] 11921 Slauson Ave. Santa Fe Springs, CA. 90670 (800) 227-4116 FAX (888) 771-7713



**PAINT DECAL
(2 PLACES)
P/N 267338-01**

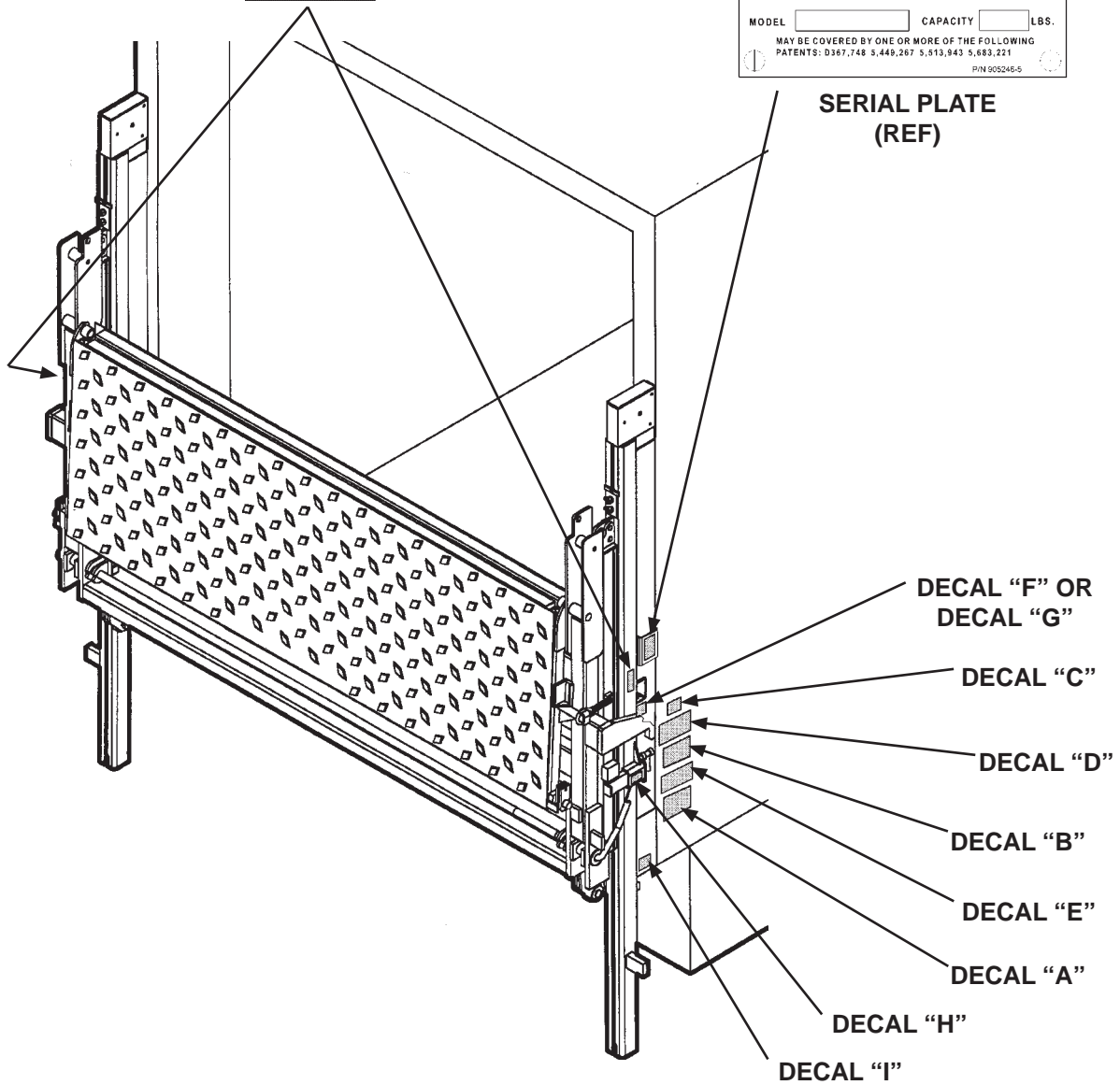
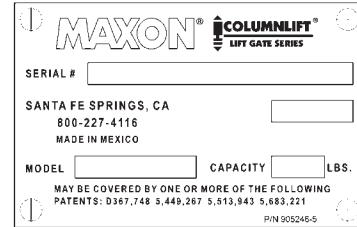

SAFETY INSTRUCTIONS

Read all decals and operation manual before operating liftgate.

1. Do not use liftgate unless you have been properly instructed and have read, and are familiar with, the operating instructions.
2. Be certain vehicle is properly and securely braked before using the liftgate.
3. Always inspect this liftgate for maintenance or damage before using it. Do not use liftgate if it shows any sign of damage or improper maintenance.
4. Do not overload
5. Make certain the area in which the platform will open and close is clear before opening or closing the platform.
6. Make certain platform area, including the area in which loads may fall from platform, is clear before and at all times during operation of liftgate.
7. This liftgate is intended for loading and unloading of cargo only. Do not use this liftgate for anything but its intended use.

(A)

WARNING

Read this information carefully.

- Improper operation of this Liftgate can result in serious personal injury. If you do not have a copy of the operating instructions, please obtain them from your employer, distributor, or lessor before you attempt to operate Liftgate.
- If there are signs of improper maintenance, damage to vital parts, or slippery platform surface, do not use the Liftgate until these problems have been corrected.
- If you are using a pallet jack, be sure it can be maneuvered safely.
- Do not operate a forklift on the platform.
- Do not allow any part of yours or your helper's body to be placed under, within, or around any portion of the moving Liftgate, or its mechanisms, or in a position that would trap them between the platform and the ground or truck when the Liftgate is operated.
- If a helper is riding the platform with you, make sure you are both doing so safely and that you are not in danger of coming in contact with any moving or potentially moving obstacles.
- **USE GOOD COMMON SENSE**
- If load appears to be unsafe, do not lift or lower it.

For a free copy of other manuals that pertain to this model Liftgate, please visit our website at www.maxonlift.com or call Customer Service at (800) 227-4116.

(B)

THE MAXIMUM CAPACITY OF THIS LIFT IS

_____ POUNDS

WHEN THE LOAD IS CENTERED ON THE LOAD CARRYING PLATFORM

(C)

WARNING

Liftgate hazards can result in crushing or falling.

Keep hands and feet clear of pinch points.

If riding liftgate, make sure load is stable and footing is solid.

Read and understand all instructions and WARNINGS before use.

(D)

CAUTION

Always stand clear of platform area.

P/N 268386-01 (E)

CAUTION

To prevent damage, stow Liftgate under hydraulic pressure & push slide bar under stop. Never rest the stop on slide bar.

(H)

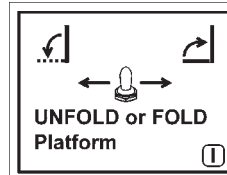
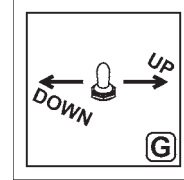
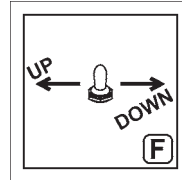

(FOR HYDRAULIC CLOSER, ONLY)

DECAL SHEET
FIG. 9-1

MODEL	ORDER P/N
RC-2 CAM CLOSER	268385-01
RC-3 CAM CLOSER	268385-02
RC-4 CAM CLOSER	268385-03
RC-5 CAM CLOSER	268385-04
RC-6 CAM CLOSER	268385-05

DECAL SHEET PART NUMBERS
TABLE 9-1

MODEL	ORDER P/N
RC-2 HYD CLOSER	268386-01
RC-3 HYD CLOSER	268386-02
RC-4 HYD CLOSER	268386-03
RC-5 HYD CLOSER	268386-04
RC-6 HYD CLOSER	268386-05

DECAL SHEET PART NUMBERS
TABLE 9-2

MAXON® 11921 Slauson Ave. Santa Fe Springs, CA. 90670 (800) 227-4116 FAX (888) 771-7713

PERIODIC MAINTENANCE

QUARTERLY MAINTENANCE SCHEDULE

1. Do the **CHECKING HYDRAULIC FLUID** procedure in the **PERIODIC MAINTENANCE** section.
2. Check all hoses and fittings for chafing and fluid leaks. Replace if necessary.
3. Check electrical wiring for chafing and make sure wiring connections are tight and free of corrosion. Apply dielectric grease to electrical connections.
4. Check that all **WARNING and instruction decals** are in place. Also, make sure decals are clean, legible, and undamaged.
5. Check if nuts and bolts are tight. Tighten if necessary.
6. Check for rust and oily surfaces on Liftgate. If there is rust or oil on Liftgate or if the Liftgate is dirty, clean it off. Touch up the paint where bare metal is showing.
7. Inspect the wire ropes. Check for broken wire strands and check both ends of each rope for corrosion.
8. Check for excessive wear and broken welds. See **PARTS BREAKDOWN** section for replacement parts.
9. Grease the Liftgate where grease fittings are provided.
10. Make sure both columns are free of grease where the runners roll inside the columns.

MAXON[®]

11921 Slauson Ave. Santa Fe Springs, CA. 90670 (800) 227-4116 FAX (888) 771-7713

QUARTERLY MAINTENANCE CHECKLIST

PM Interval: Quarterly

Date: / /

Equipment:

W/O #

Location:

Mechanic:

Serial #

Model #

Check Appropriate Box. “ ”

MAXON 1 st , 2 nd and 3 rd Quarter Liftgate PM Procedures				
Satisfactory	Repair Required	Corrected	1	Visual inspection. Inspect Liftgate for loose or missing bolts, roll pins, screws, cracked welds or other damage.
Satisfactory	Repair Required	Corrected	2	Check zerk fittings. Grease if necessary. Lube all rotation areas.
Satisfactory	Repair Required	Corrected	3	Check emergency brake oil (see FIG. 9-X).
Satisfactory	Repair Required	Corrected	4	Check oil level in reservoir. Oil should be 1" from top of tank with Liftgate on ground. Use Mobil SHC ATF, or acceptable cold weather hydraulic oil.
Satisfactory	Repair Required	Corrected	5	Check hydraulic system: hoses, fittings, cylinder(s), etc. for leaks.
Satisfactory	Repair Required	Corrected	6	Inspect electrical wiring for corrosion, tightness and undamaged insulation.
Satisfactory	Repair Required	Corrected	7	Inspect wire ropes. Replace if 6 or more wire ropes are broken 2-1/2" or more in length (see FIG. 9-X).
Satisfactory	Repair Required	Corrected	8	Inspect sheaves for wear or damage.
Satisfactory	Repair Required	Corrected	9	Check operation of platform safety devices (see FIG. 9-X).
Satisfactory	Repair Required	Corrected	10	Check operation decals: missing, worn, illegible, etc. (see FIG. 9-X).

For more detailed information, please refer to the product maintenance manuals. Use only genuine Maxon replacement parts for all repairs.

MAXON[®] 11921 Slauson Ave. Santa Fe Springs, CA. 90670 (800) 227-4116 FAX (888) 771-7713

GENERAL MAINTENANCE

CHECKING HYDRAULIC FLUID

CAUTION

Keep dirt, water and other contaminants from entering the hydraulic system. Before opening the hydraulic fluid reservoir filler cap, drain plug and hydraulic lines, clean up contaminants that can get in the openings. Also, protect the openings from accidental contamination.

NOTE: Use correct grade of hydraulic fluid for your location.

+50 to +120 Degrees F - Grade ISO 32

Below + 70 Degrees F - Grade ISO 15 or MIL-H-5606

See **TABLES 13-1 & 13-2** for recommended brands.

NOTE: To check oil level in the pump reservoir, platform must be at ground level.

1. Unfold and lower platform to the ground.
2. Open the pump box cover (**FIG. 12-1**).
3. Remove the filler cap (**FIG. 12-2**). Check if hydraulic fluid is at the top of the **GRAVITY DOWN** bar on the decal (**FIG. 12-2**). If necessary, add fluid to the top of the bar. If the hydraulic fluid is contaminated, do the **CHANGING HYDRAULIC FLUID** procedure in this section of the manual.
4. Reinstall filler cap (**FIG. 12-2**).
5. Close the pump box cover (**FIG. 12-1**).

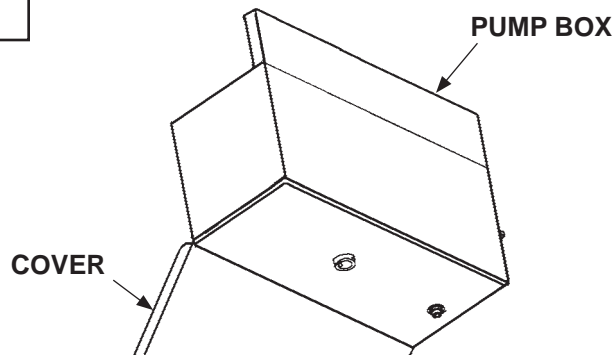

PUMP BOX WITH OPEN COVER
FIG. 12-1

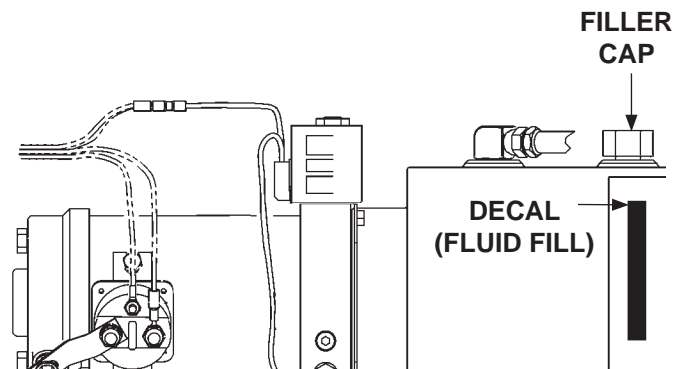

CHECKING FLUID LEVEL
(GRAVITY DOWN PUMP SHOWN - USED ON
RC WITH CAM PLATFORM CLOSER)
FIG. 12-2

ISO 32 HYDRAULIC OIL	
RECOMMENDED BRANDS	PART NUMBER
AMSOIL	AWH-05
CHEVRON	HIPERSYN 32
KENDALL	GOLDEN MV
SHELL	TELLUS S2 V32
EXXON	UNIVIS N-32
MOBIL	DTE-13M, DTE-24, HYDRAULIC OIL-13

TABLE 13-1

ISO 15 OR MIL-H-5606 HYDRAULIC OIL	
RECOMMENDED BRANDS	PART NUMBER
AMSOIL	AWF-05
CHEVRON	FLUID A, AW-MV-15
KENDALL	GLACIAL BLU
SHELL	TELLUS S2 V15
EXXON	UNIVIS HVI-13
MOBIL	DTE-11M
ROSEMEAD	THS FLUID 17111

TABLE 13-2

GENERAL MAINTENANCE

CHANGING HYDRAULIC FLUID

CAUTION

Keep dirt, water and other contaminants from entering the hydraulic system. Before opening the hydraulic fluid reservoir filler cap, drain plug and hydraulic lines, clean up contaminants that can get in the openings. Also, protect the openings from accidental contamination.

NOTE: Use correct grade of hydraulic fluid for your location.

+50 to +120 Degrees F - Grade ISO 32

Below + 70 Degrees F - Grade ISO 15 or MIL-H-5606

See **TABLES 13-1 & 13-2** for recommended brands.

NOTE: To prevent spills, drain used hydraulic fluid through a funnel into waste fluid container.

1. Open the pump box cover (**FIG. 14-1**).
2. Place empty 5 gallon bucket under drain plug (**FIG. 14-1**).
3. Open and raise platform to vehicle bed height. Then, remove the drain plug (**FIG. 14-1**).
4. Lower the platform to ground level while draining the hydraulic fluid from system.
5. Reinstall the drain plug (**FIG. 14-1**).

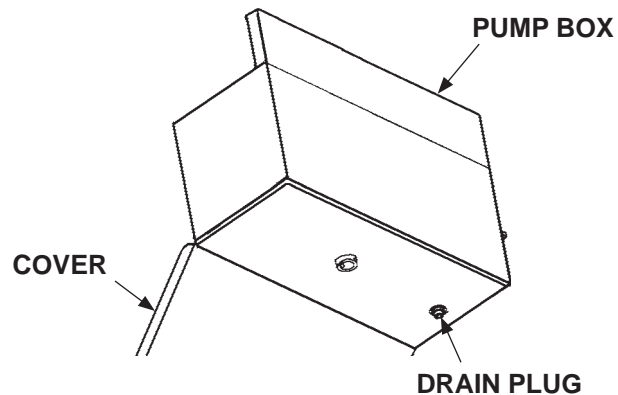

ACCESSING DRAIN PLUG
FIG. 14-1

NOTE: To check oil level in the pump reservoir, platform must be at ground level.

6. Remove the filler cap (**FIG. 14-2**). Refill reservoir to the level shown on decal (**FIG. 14-2**).
7. Reinstall filler cap (**FIG. 14-2**).

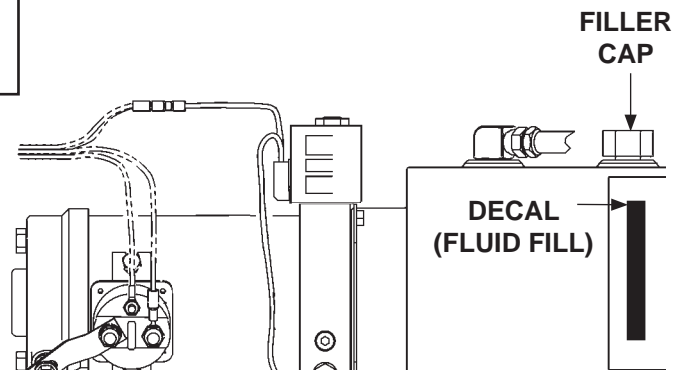

CHECKING FLUID LEVEL
(GRAVITY DOWN PUMP SHOWN FOR RC
WITH CAM PLATFORM CLOSER)
FIG. 14-2

8. Close the pump box cover (**FIG. 14-1**).

REPLACING PARTS

REPLACING CYLINDER SEALS

NOTE: Small amounts of seepage from cylinder seal is normal, but if oil is gushing from the breather or rod end, it is considered a leak.

1. To check for cylinder seal leakage, remove the cover from the main frame assembly. The platform should cycle up and down several times.

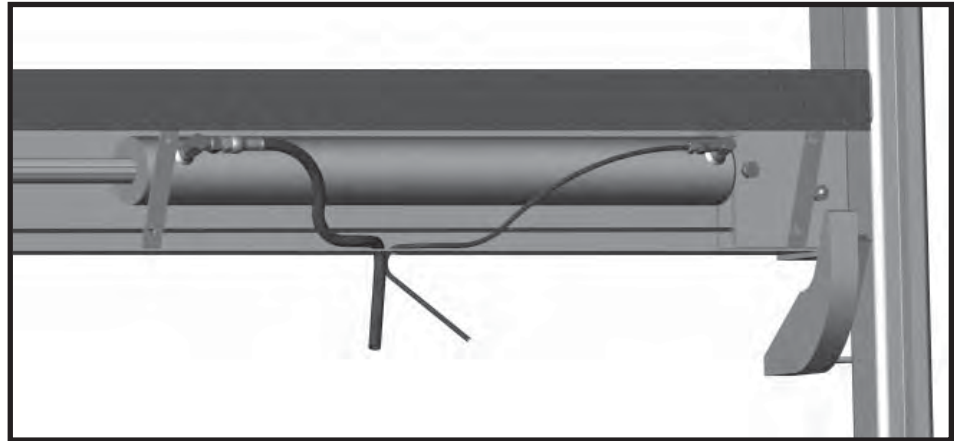

FIG. 15-1

2. If there is a leak, replace the cylinder seals. Remove the cylinder from the main frame assembly and disassemble in a separate area. For cylinder removal, see **CYLINDER REPLACEMENT**. Seal kits are available from **MAXON** Industries Inc. For specific unit and model, see pro seal kit part number unit (parts breakdown).

CHECK VALVE

If the check valve does not operate correctly, it may be slightly open. Adjust the check valve by turning clockwise. If necessary, remove the check valve to clean and inspect.

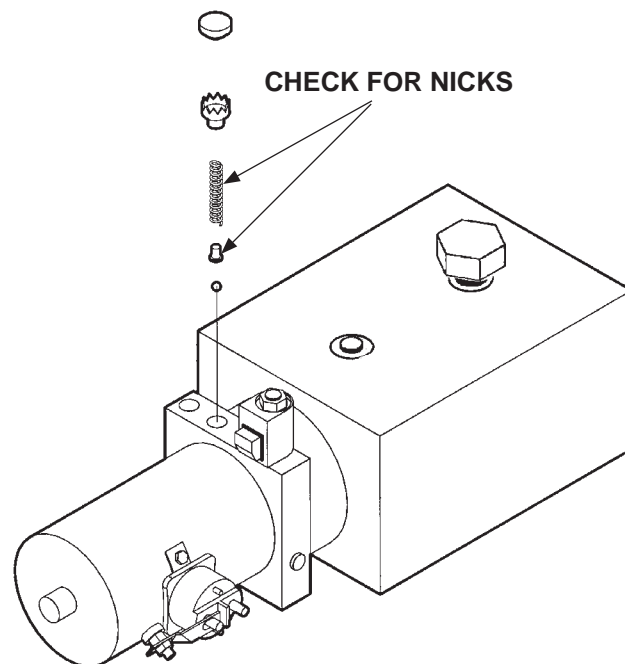

FIG. 15-2

REPLACING PARTS

WIRE ROPE REMOVAL

NOTE: Since both wire ropes usually wear out at the same time, it is recommended that both wire ropes be replaced at the same time. The following instructions cover changing both wire ropes. If only one wire rope is being replaced, use the appropriate sections for that wire rope.

NOTE: Save all removed parts, except the parts that need to be replaced. The saved parts can be reused.

1. Lower platform to ground. Remove two bolts from the runner lug and the cable link adapter.

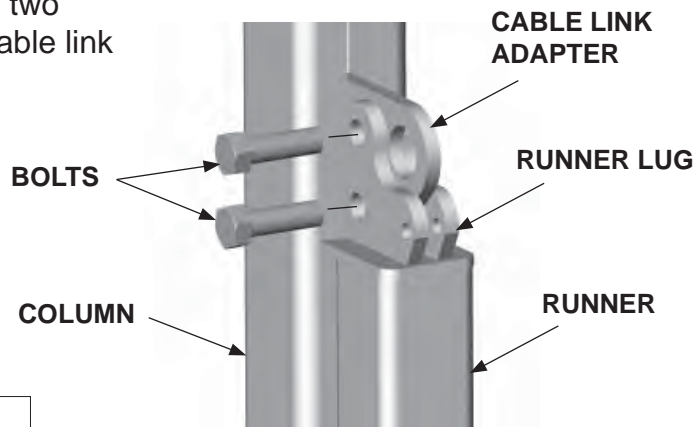

FIG. 16-1

2. Remove the sheave covers from top of column. Before removing the 3/8" bolts holding the stop plates to the column, wedge a screwdriver underneath the plates. Loosen or remove bolts and lock washers and ease stop plates out of the column.

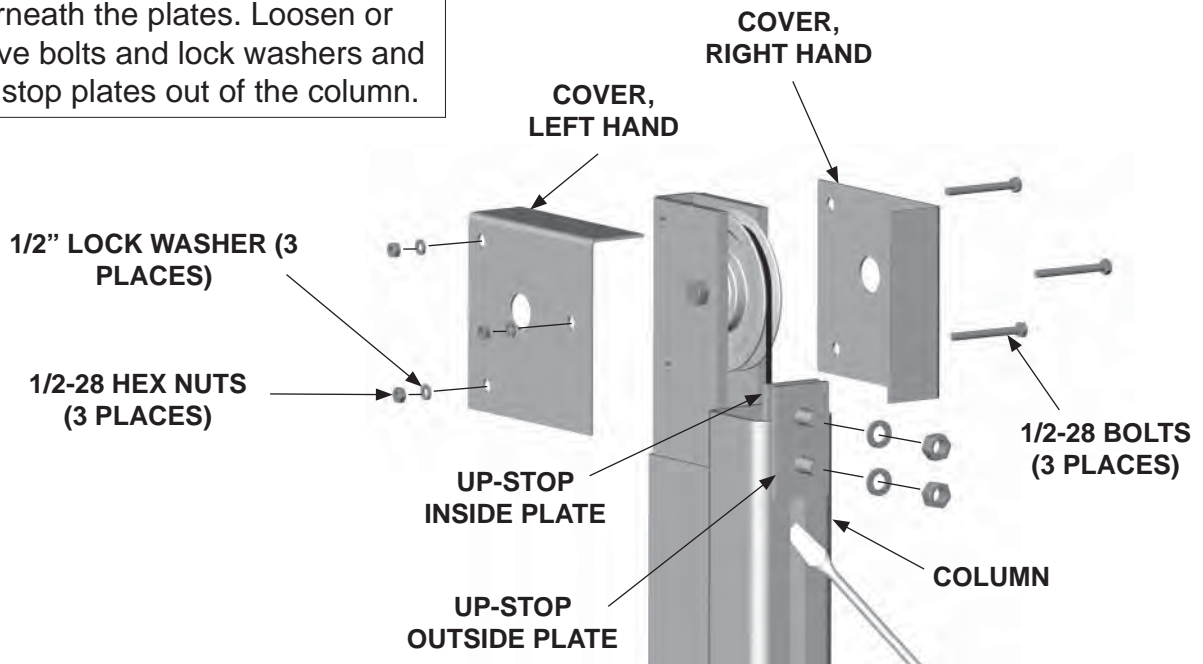

FIG. 16-2

⚠ WARNING

All the sheaves in the RC are bolted on with special bolts. No substitutions allowed. If replacements are needed, order only the part numbers listed in these instructions.

3. Remove the sheaves from the tops of the column assemblies. Check the bolts for wear in the area where the sheave has been rotating. If the bolts are worn, they must be replaced. For RC-2, use P/N 202438. For RC-3, RC-4, RC-5, and RC-6, use P/N 202465.
4. Locate the cable. Inspect the sheaves for nicks or chips. If they need to be replaced, see **PARTS BREAKDOWN** to obtain the correct part number.

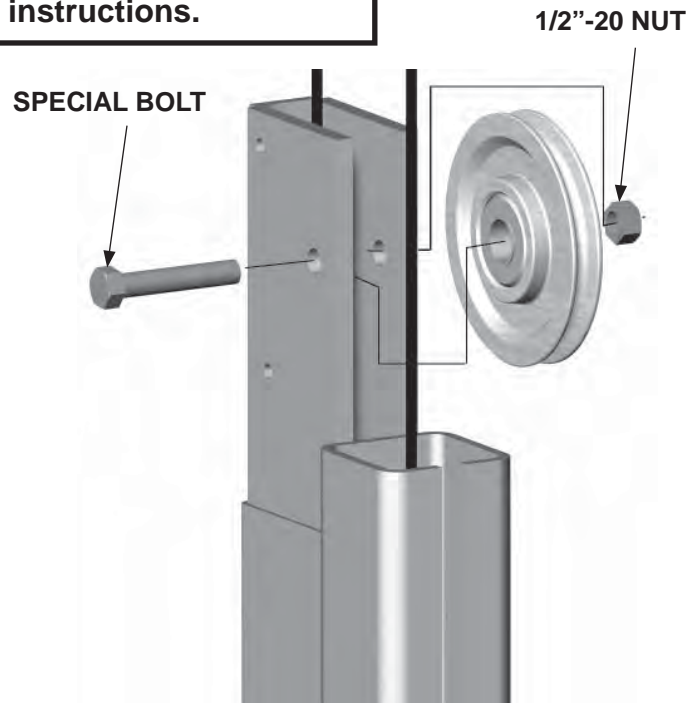

FIG. 17-1

NOTE: It is not necessary to remove the lower bolt from the brake assembly unless brake is being replaced.

5. With the stops removed, the brake assembly can be pulled out of the column. The wire rope end fitting can now be removed from the upper portion of the brake assembly. Let the wire rope hang out over the top of the column assembly.

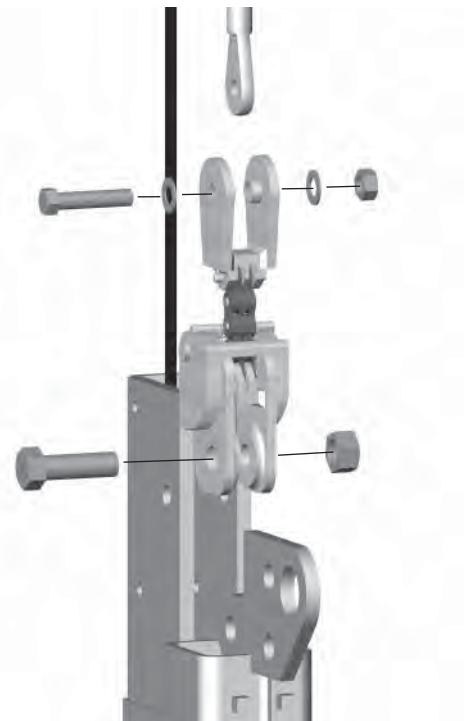

FIG. 17-2

REPLACING PARTS

WIRE ROPE REMOVAL - Continued

6. Remove main frame cover. If **both wire ropes** need to be removed, **all five sheaves** (left column sheaves, the two cylinder sheaves and the right column sheave) will need to be removed from inside the main frame assembly. Inspect sheaves for excessive wear and grooves. Replace if necessary.

NOTE: For left column sheaves, hold nut with a wrench or finger tips. Remove the bolt and lock washer.

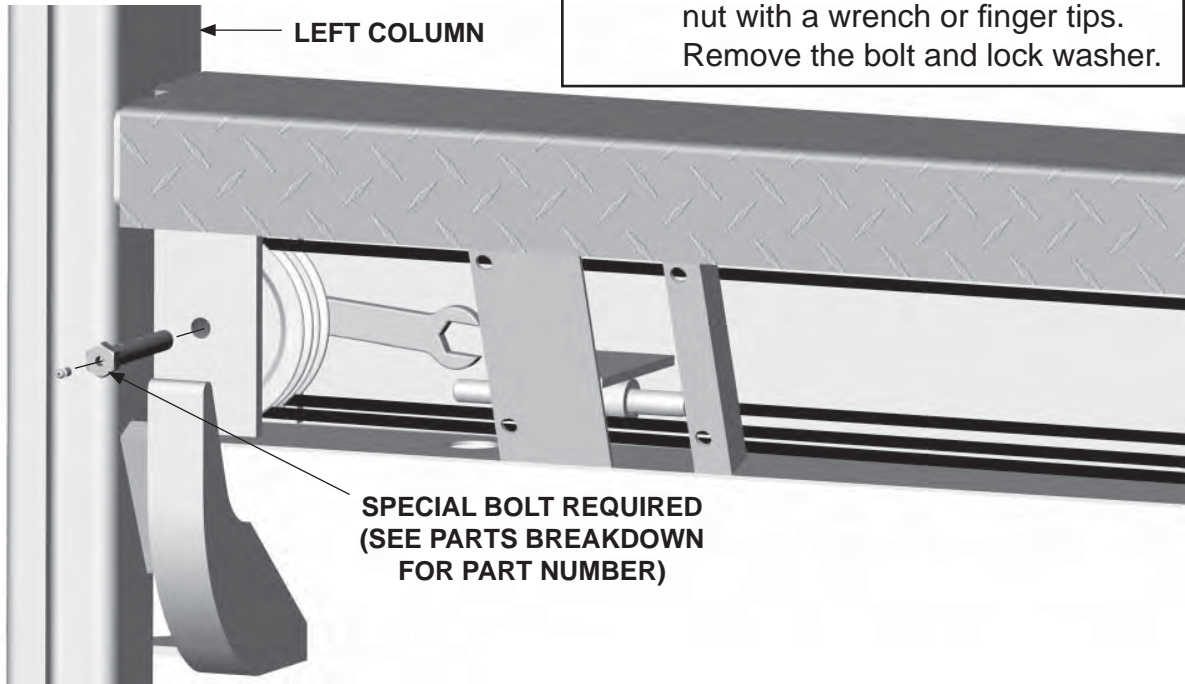

FIG. 18-1

7. Remove both sheaves and spacer washers (washers located between the sheaves for the **RC-2** and **RC-3** only) from the anchor plates.

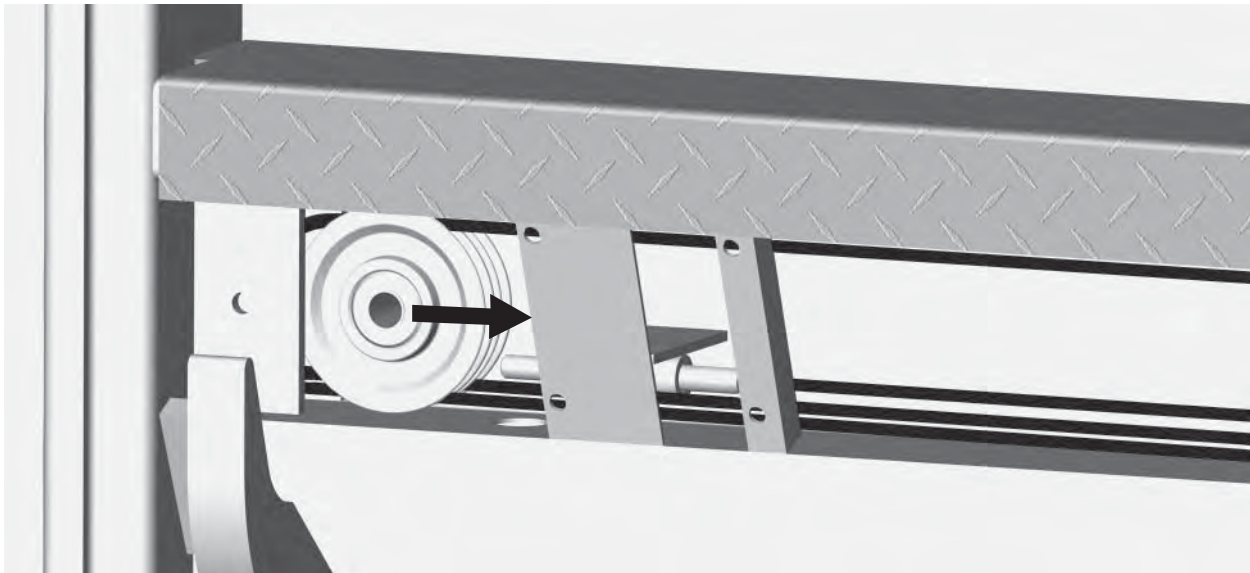

FIG. 18-2

MAXON[®]

11921 Slauson Ave. Santa Fe Springs, CA. 90670 (800) 227-4116 FAX (888) 771-7713

NOTE: Lightly grease the floor of the cylinder housing where the cylinder and sheave assembly slides.

8. Remove the bolt and lock washer holding the sheaves in the cylinder anchor plates. (The sheave uses a special bolt. See the **PARTS BREAKDOWN** section for part number.) Pull the sheaves out of the anchor plates. At the same time, slide the wire rope end fitting to the left. The sheaves can now be removed.

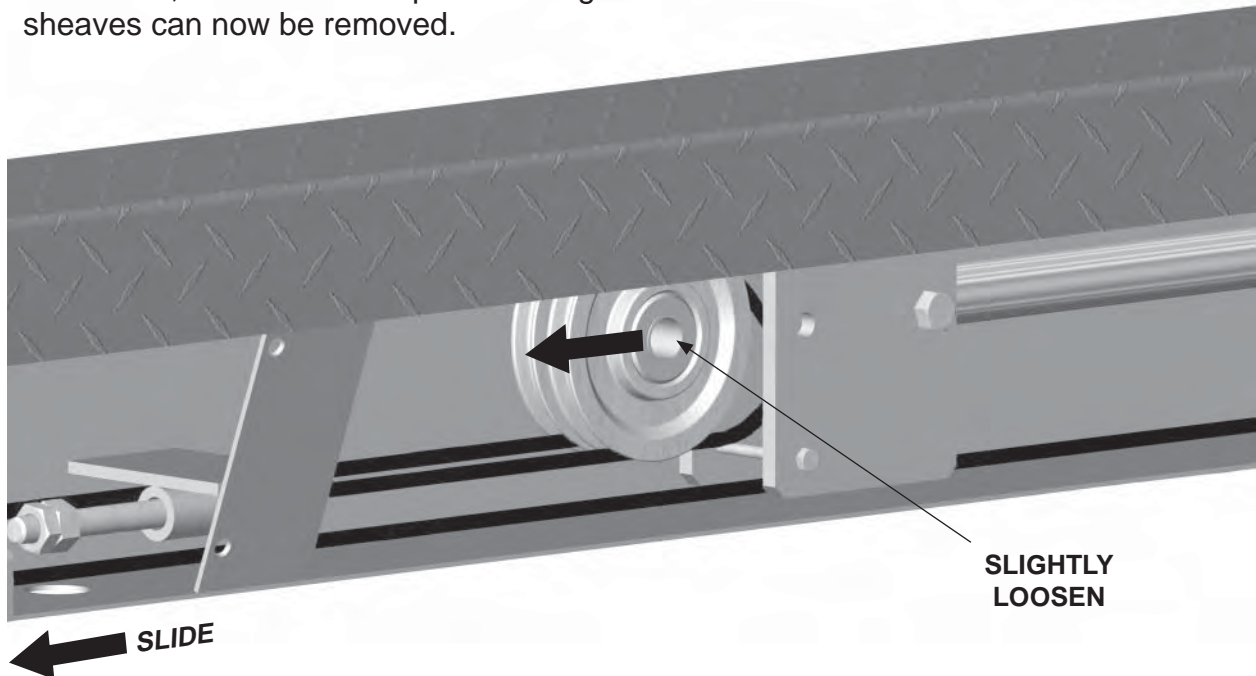

FIG. 19-1

9. To obtain access to the right column sheave, remove the bolt holding the butt end of the cylinder in the anchor plates. Slide the cylinder assembly to the left.

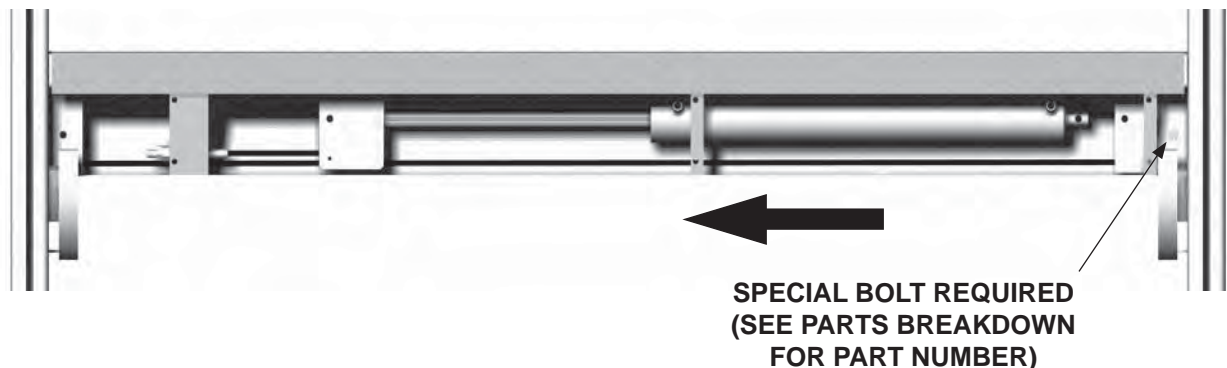

FIG. 19-2

REPLACING PARTS

WIRE ROPE REMOVAL - Continued

10. The sheave bolt removal is similar to other sheave bolt removals. Slide the sheave out of the anchor plates.



FIG. 20-1

11. Slide the cylinder assembly to the right.



FIG. 20-2

12. Remove the nuts from both wire rope end fittings. Pull the wire rope end fittings out of the tubes. From the top of each column assembly, pull the wire ropes up and out of the unit.

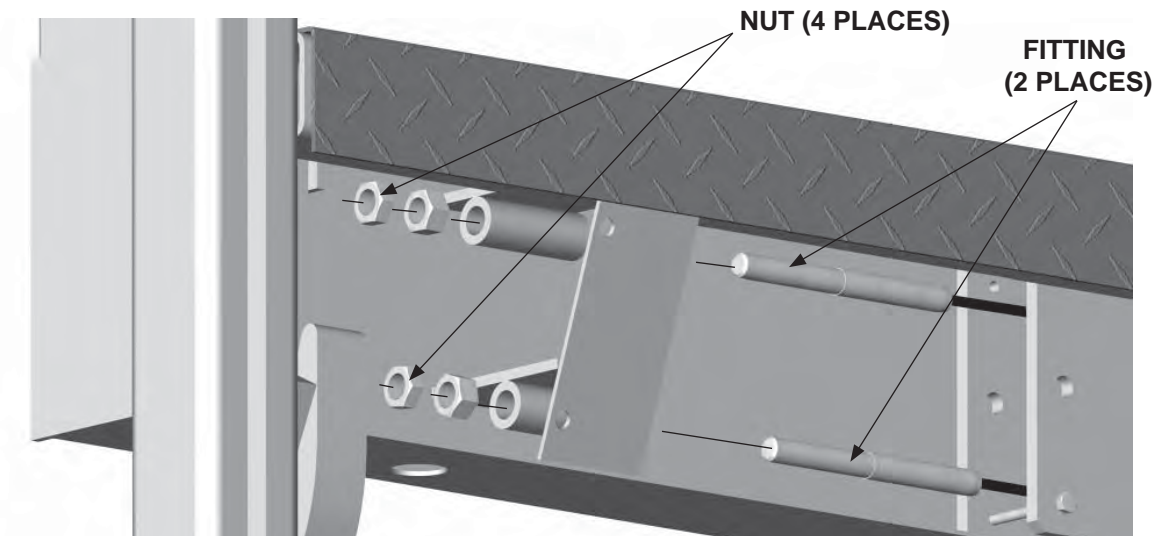

FIG. 20-3

WIRE ROPE REPLACEMENT

1. Install the left hand wire rope first. This is the shortest of the two wire ropes. Insert the wire rope end fitting (threaded end) down into the cable enclosure.

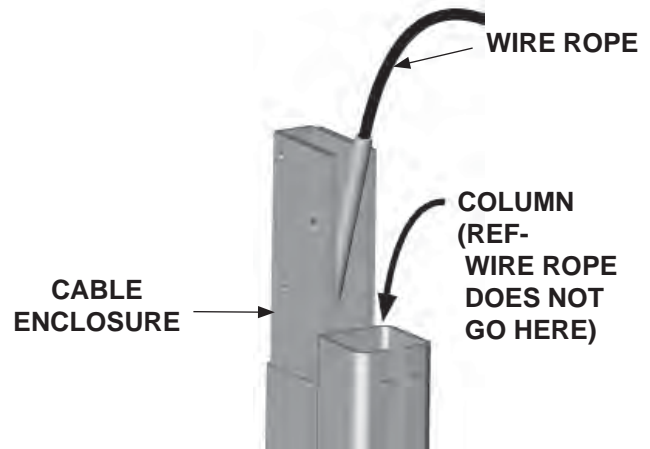

FIG. 21-1

2. When the wire rope end reaches the bottom of the column, use a length of bent wire to fish the wire rope out into the main frame assembly.

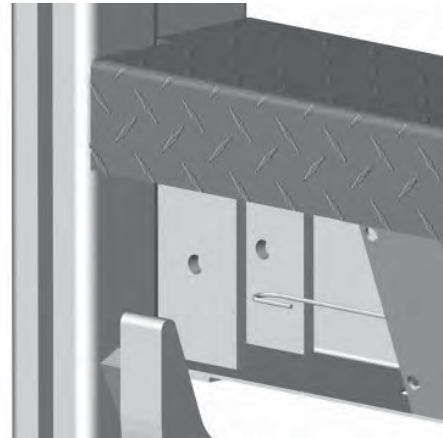

FIG. 21-2

3. Pull approximately 3 feet of wire rope into the main frame assembly. Insert the threaded end of the wire rope into the top tube of the wire rope end retainer assembly. Install one nut to the wire rope end.

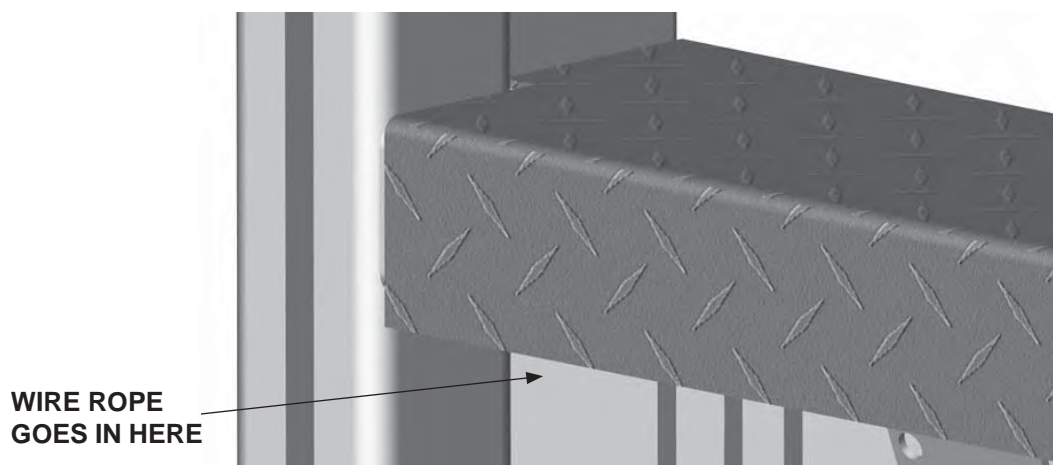

FIG. 21-3

REPLACING PARTS

WIRE ROPE REPLACEMENT - Continued

4. Install the sheave to the top of the left column assembly. Install the wire rope fitting to the runner links.

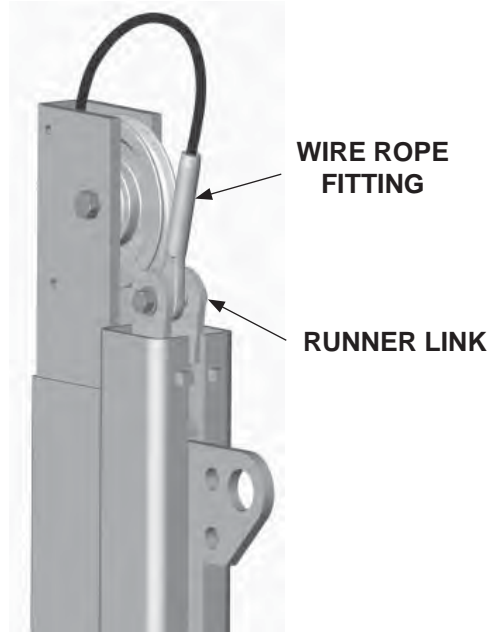

FIG. 22-1

5. For the longer wire rope installation on the right hand column, use the same procedure used for the left hand column. Pull approximately 11 to 12 feet of wire rope into the main frame assembly. See FIG. 26-2.

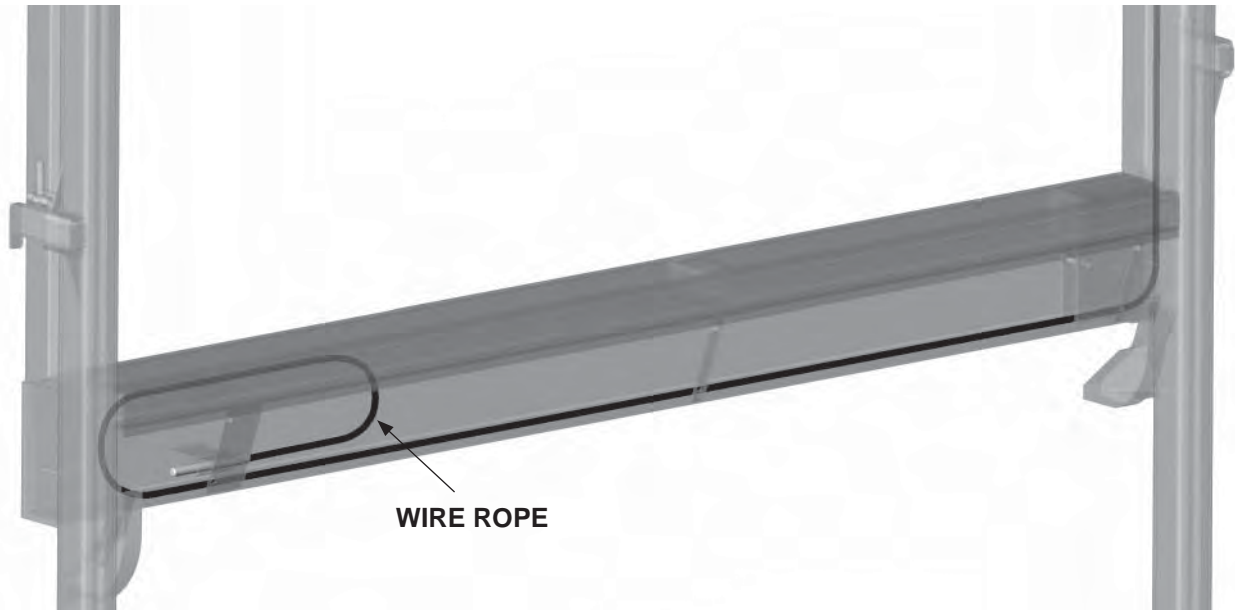

FIG. 22-2

MAXON[®]

11921 Slauson Ave. Santa Fe Springs, CA. 90670 (800) 227-4116 FAX (888) 771-7713

6. Insert the threaded end of the wire rope into the bottom tube of the wire rope end retainer assembly. Install one nut to the wire rope ends.

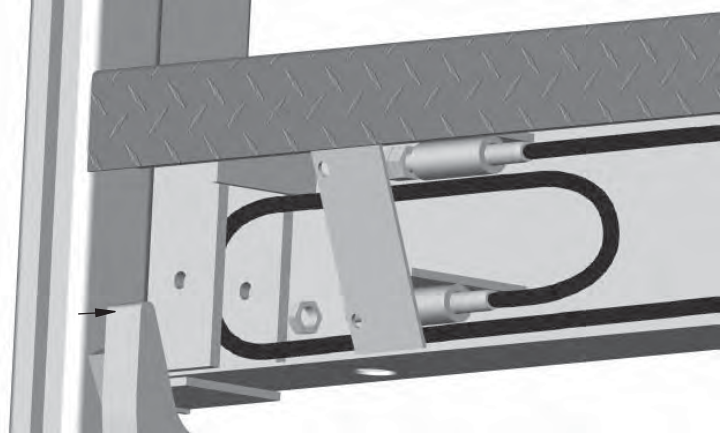

FIG. 23-1

7. For the right side pulley, use the same procedure used on the left side pulley.

NOTE: The sheaves on **RC-2** and **RC-3** are bolted and unbolted as shown in the illustration on next page.

NOTE: Lock washer is positioned under head of bolt.

8. Install the 2 left column sheaves inside the main frame assembly. Be sure the wire ropes are seated in the grooves of the sheaves. To start the nut on the bolt, hold the nut between fingers and insert behind the sheave anchor plate. Finish tightening nut with a wrench.

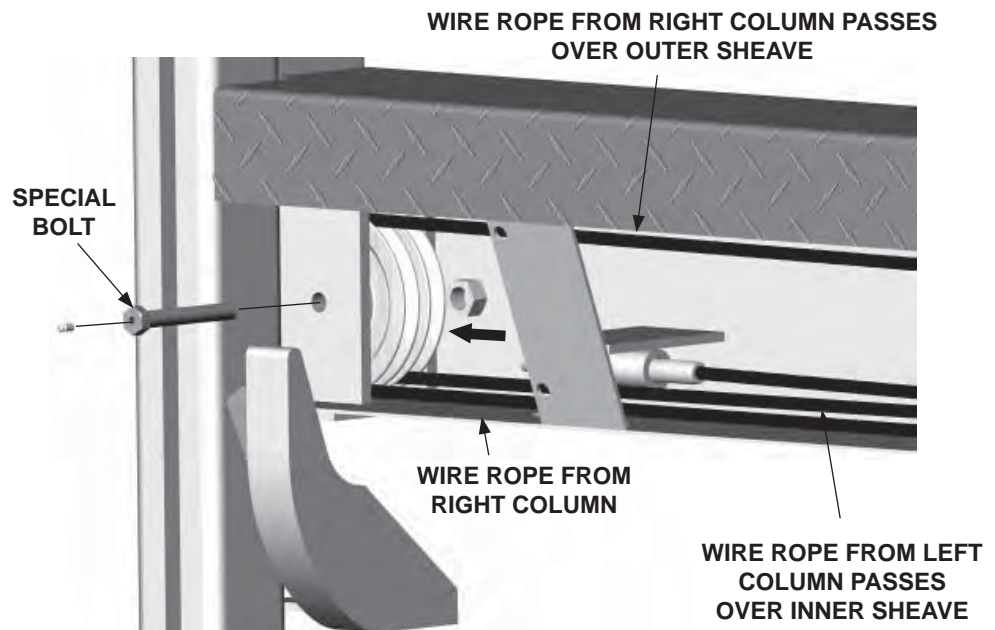

FIG. 23-2

MAXON[®]

11921 Slauson Ave. Santa Fe Springs, CA. 90670 (800) 227-4116 FAX (888) 771-7713

REPLACING PARTS

WIRE ROPE REPLACEMENT - Continued

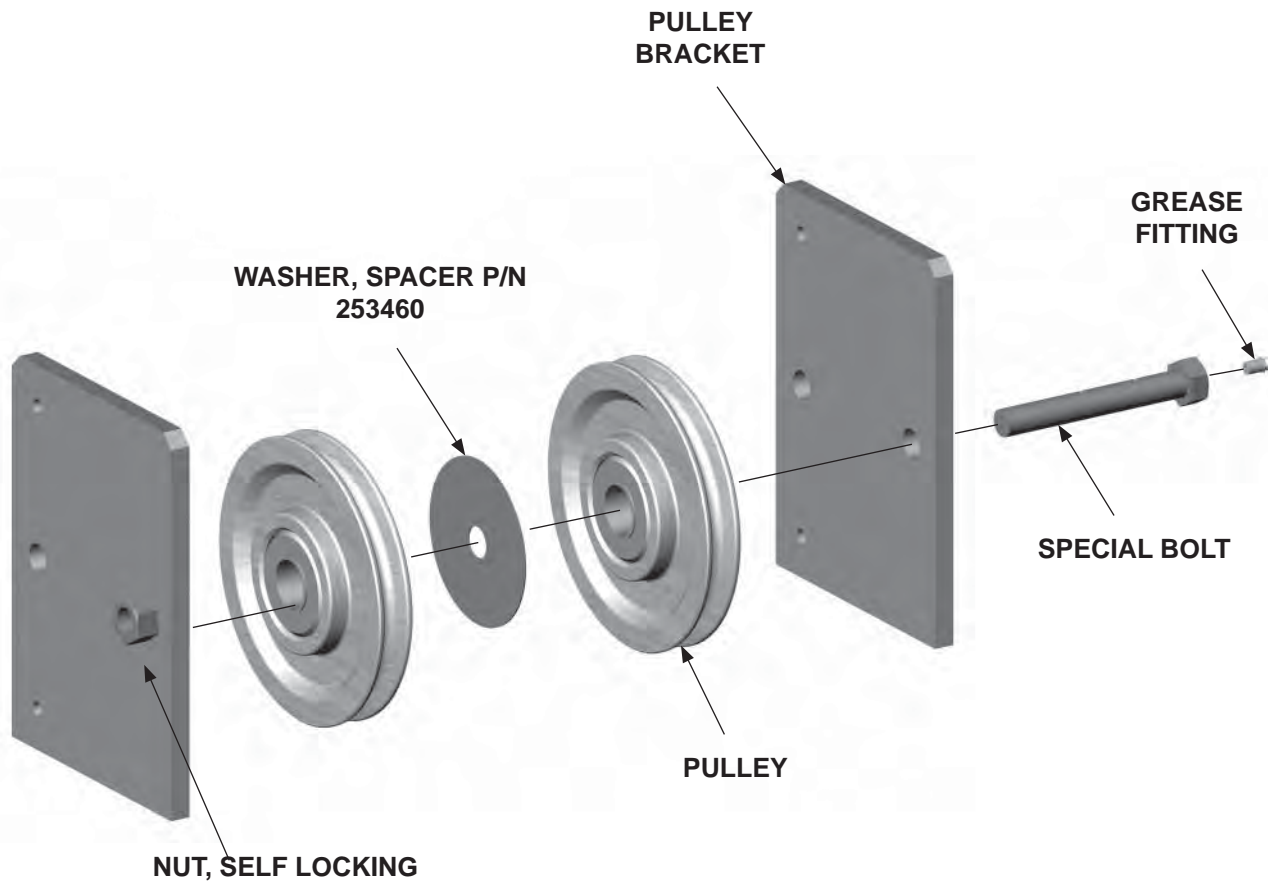

**SHEAVES ARE SHOWN FOR RC-2 & RC-3 CYLINDER ROD
END & LOWER LEFT HAND PULLEY BRACKET**

FIG. 24-1

9. Move cylinder assembly to the left. Install the right column sheave. Be sure the wire rope is seated in the groove. The right column sheave installation is similar to the left column sheave installation.

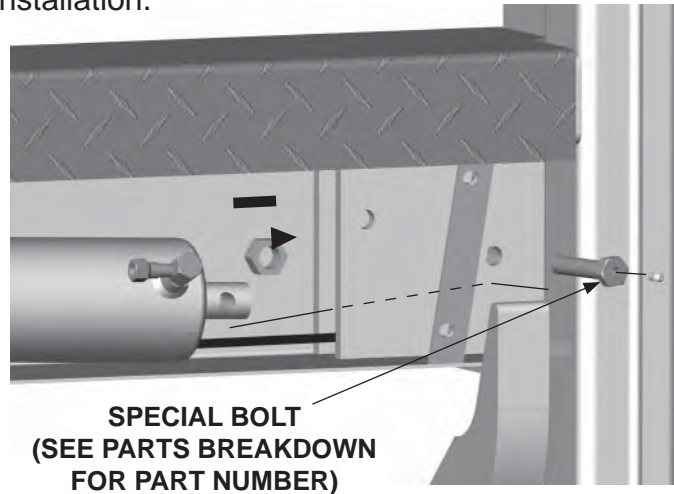

FIG. 25-1

10. Install the butt end of the cylinder to the right hand anchor plate. This bolt is identical to the right hand sheave bolt. **It is a special bolt. No substitutions allowed.**
11. Install the two cylinder anchor plate sheaves. Make sure that **both wire ropes** are seated in the grooves. The sheave bolt **is a special bolt. No substitutions allowed.**
12. The right and left hand runners can now be unclamped and lowered down the column assemblies. This will take up most of the slack in the wire rope.

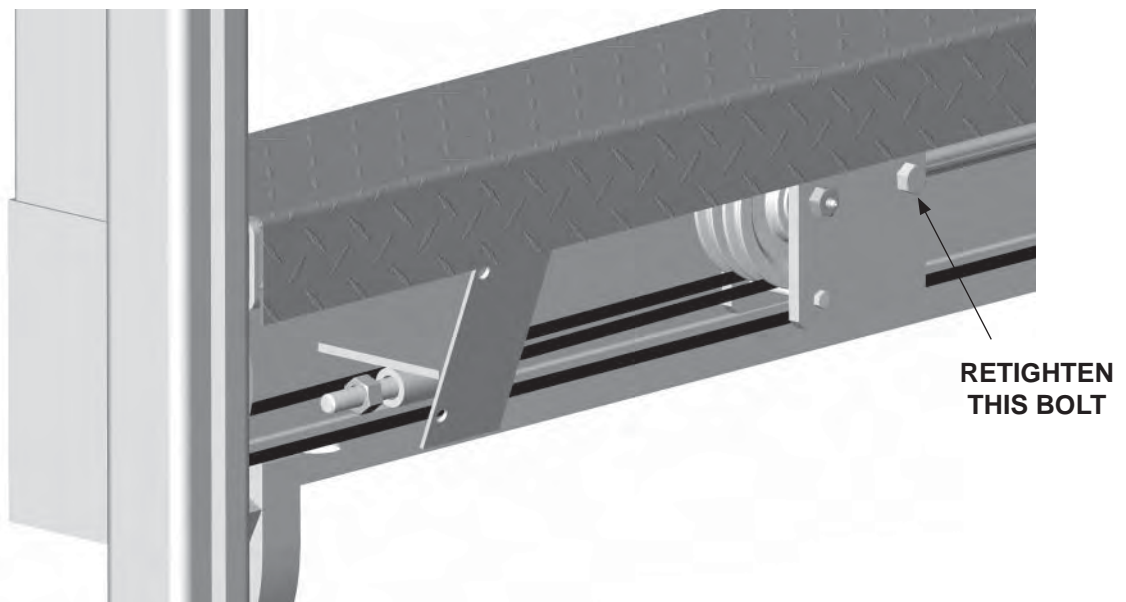

FIG. 25-2

REPLACING PARTS

WIRE ROPE REPLACEMENT - Continued

13. Install the remaining two nuts to the cable end fittings. Run the nuts down on the cable fittings to take up the remaining slack.

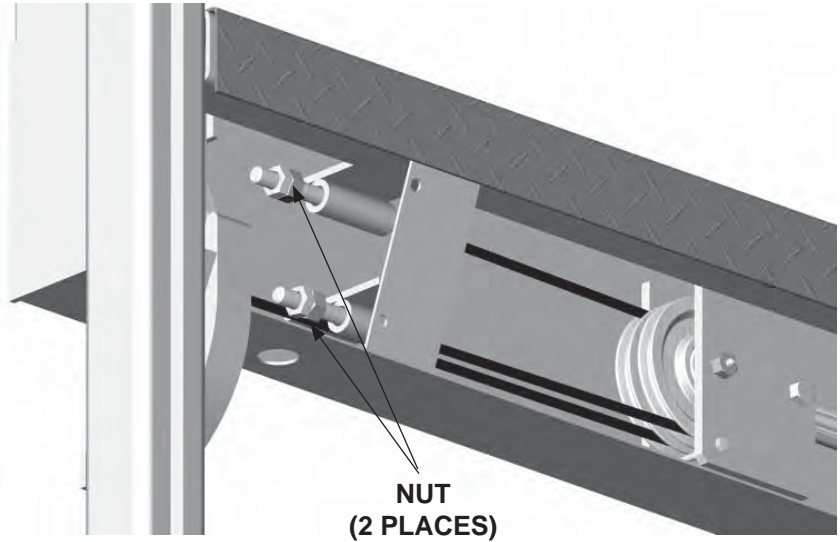

FIG. 26-1

⚠ WARNING

Check that all bolts are tight before operating Liftgate.

NOTE: A screwdriver may be used to ease stop plates into column. Install nuts and lock washers.

NOTE: The outside stop plates are the same for all **MAXON** Raillifts.

14. Install stop plate in the column. Plate should be below the tops of the welded blocks and flush.

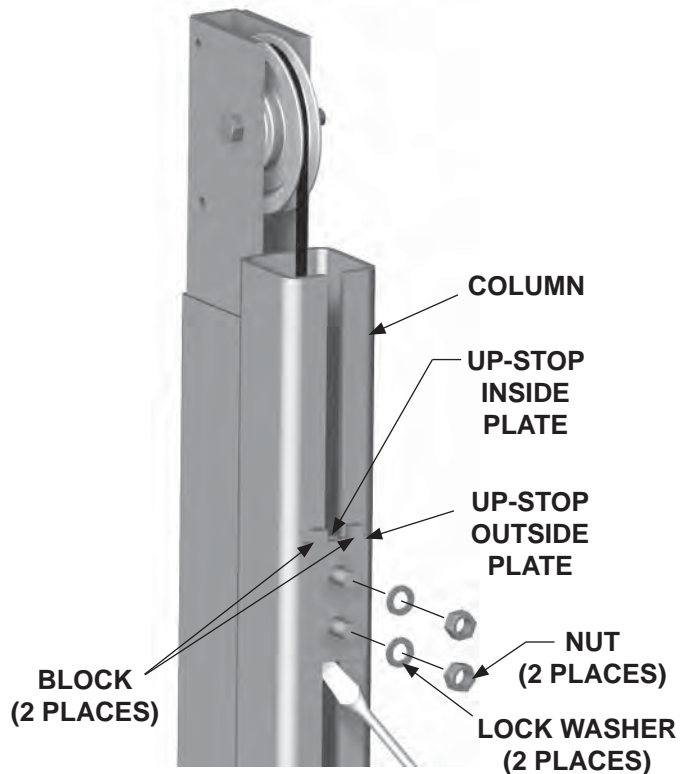
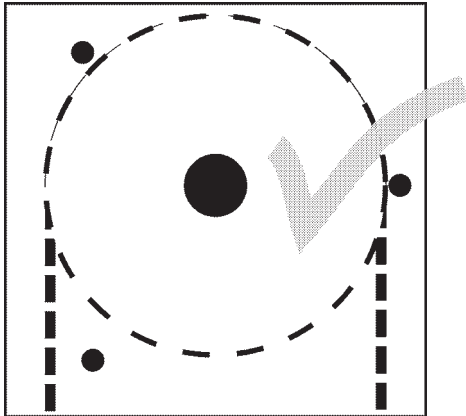

FIG. 26-2

CAUTION

To prevent damage from sheave cover bolt after covers are installed, make sure wire is seated in the v-groove on the sheave. Do not allow the wire rope to be placed between the rear cover bolt and the right hand cover.



**CORRECT PATH
FOR WIRE ROPE
FIG. 27-1**

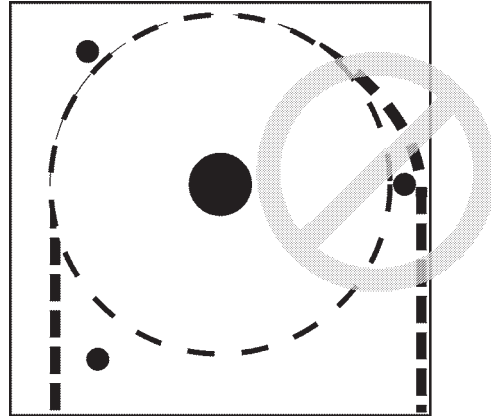

**INCORRECT PATH
FOR WIRE ROPE
FIG. 27-2**

15. Bolt the sheave covers to the column as shown in illustration. Observe the **CAUTION** to ensure wire rope is on the right path while bolting on the sheave covers.

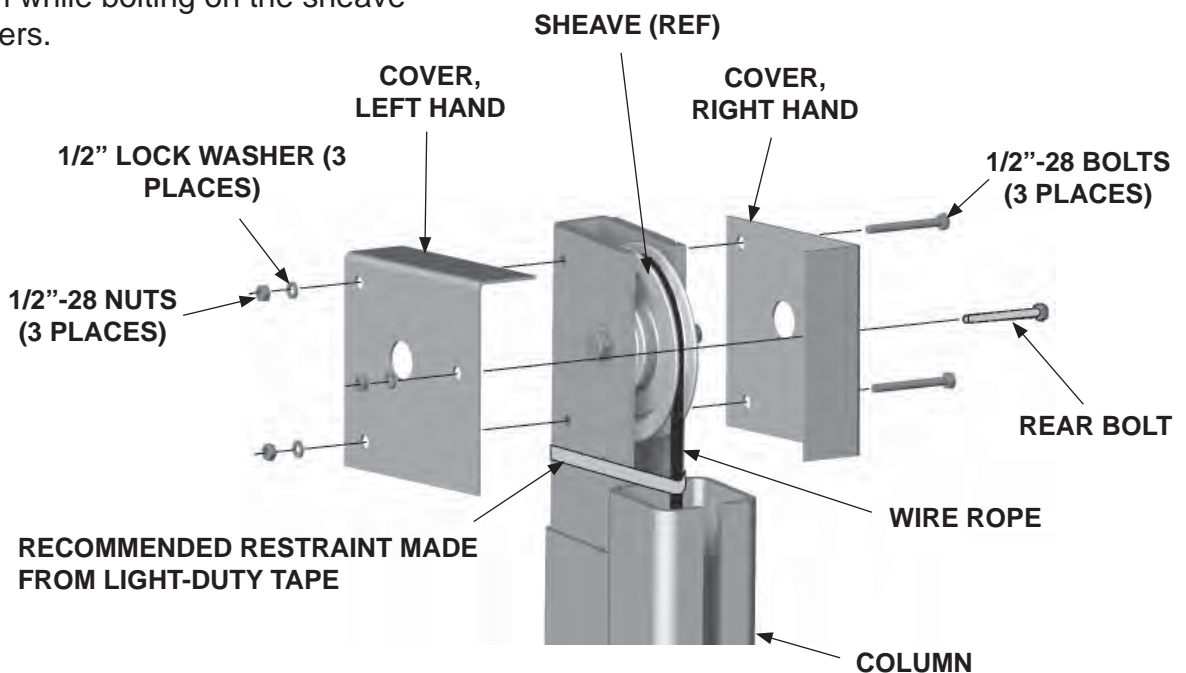

REPLACING PARTS

CYLINDER REPLACEMENT

NOTE: If the cylinder bolts need to be replaced, see **PARTS BREAKDOWN** for part number. **No substitutions allowed.**

1. Lower platform to ground. Remove cover from main frame assembly. Remove the cylinder bolts from the sheave anchor plates. Lower the cylinder onto the main frame.

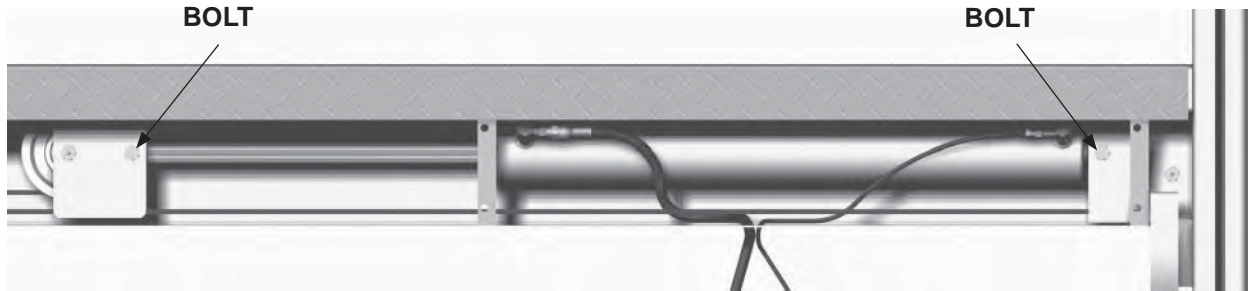

FIG. 28-1

2. Using the curbside remote control, move toggle switch to "RAISE" position to retract the cylinder shaft into the barrel. Release switch when the shaft is approximately half way retracted.

3. Disconnect hose from the cylinder.

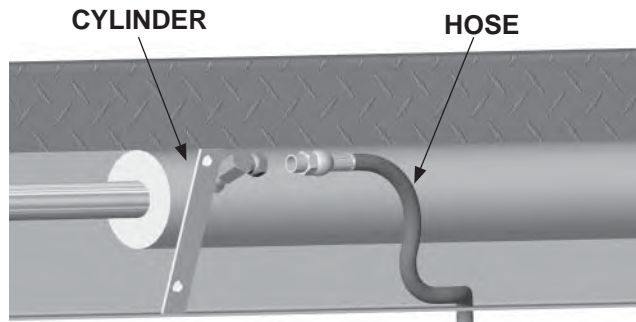

FIG. 28-2

4. The cylinder can now be removed from the main frame assembly.

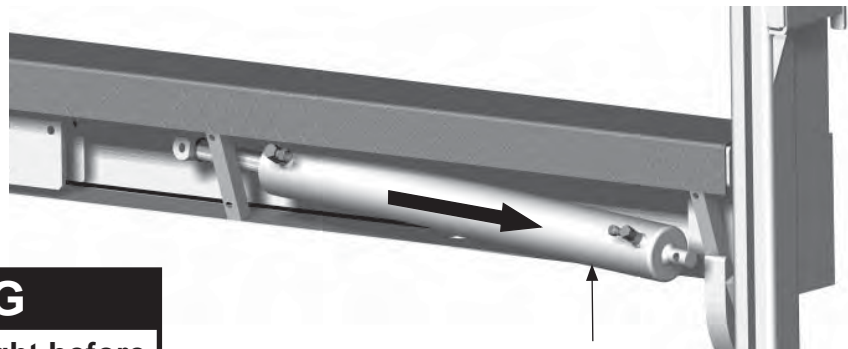

FIG. 28-3

⚠ WARNING

Check that all bolts are tight before operating Liftgate.

5. Cylinder replacement is the reverse of removal.

MAXON

11921 Slauson Ave. Santa Fe Springs, CA. 90670 (800) 227-4116 FAX (888) 771-7713

RELEASING EMERGENCY BRAKE

NOTE: If the platform will not lower on one or both sides, it may be necessary to release the emergency brake(s) on the affected side(s). Do the following procedure to release one or both of the emergency brakes.

1. Unbolt the upper sheave covers from the side of the platform that will not lower. If necessary, unbolt the upper sheave covers from both sides of the platform.
2. Unbolt the up-stop from the top of the column.
3. Being careful not to raise the Liftgate more than 1-1/2", activate the raise switch. This will retract the emergency brake cam and allow the platform to be lowered. Lower Liftgate approximately 12".
4. Bolt the up-stop in original position.
5. Lower and raise the platform several times to verify it operates correctly. Bolt the sheave covers into column.

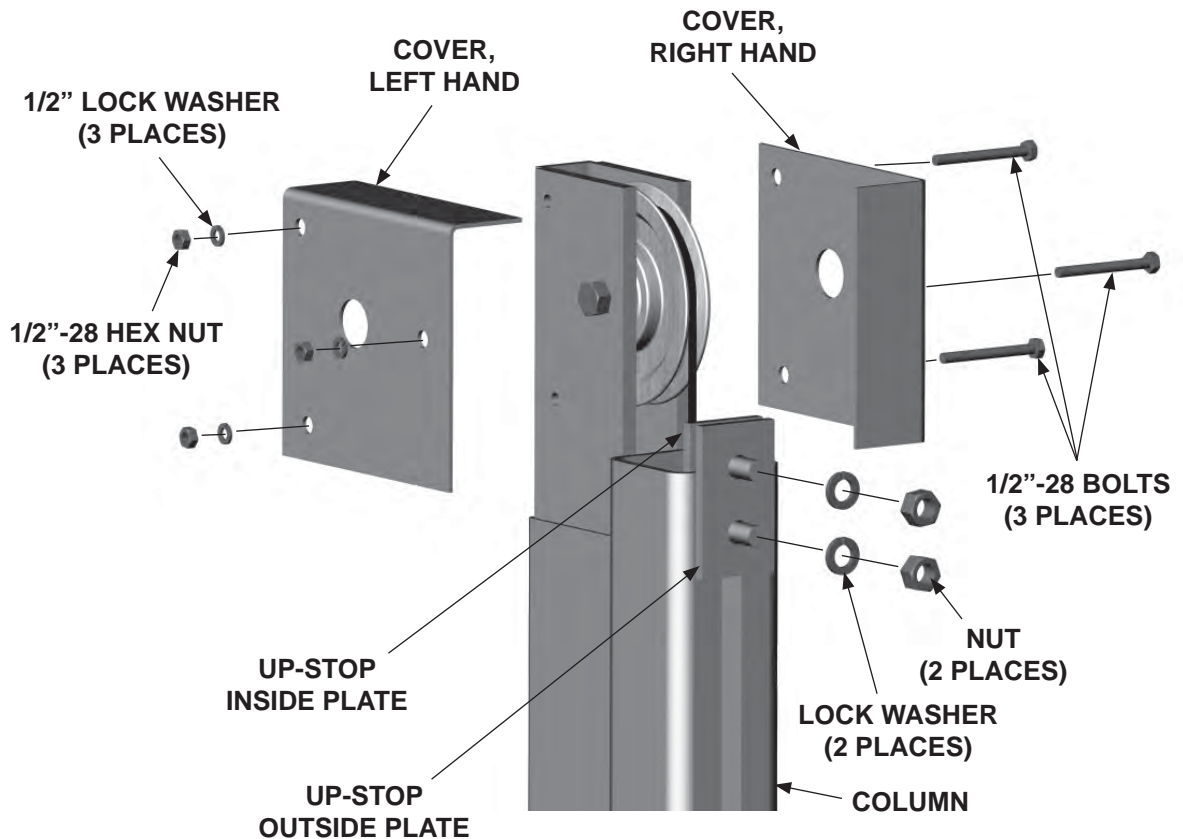

FIG.29-1

REPLACING PARTS PUMP-SHAFT, COUPLING AND FILTER

1. Drain and remove reservoir. Check filter. If filter is clean, a worn pump is indicated. Change pump assembly. For replacement parts, see **PUMP ASSEMBLY (POWER DOWN FOR HYDRAULIC CLOSER)**.
2. Inspect coupling for wear. When installing pump assembly, make sure coupling is installed to motor shaft and pump shaft is installed to coupling.

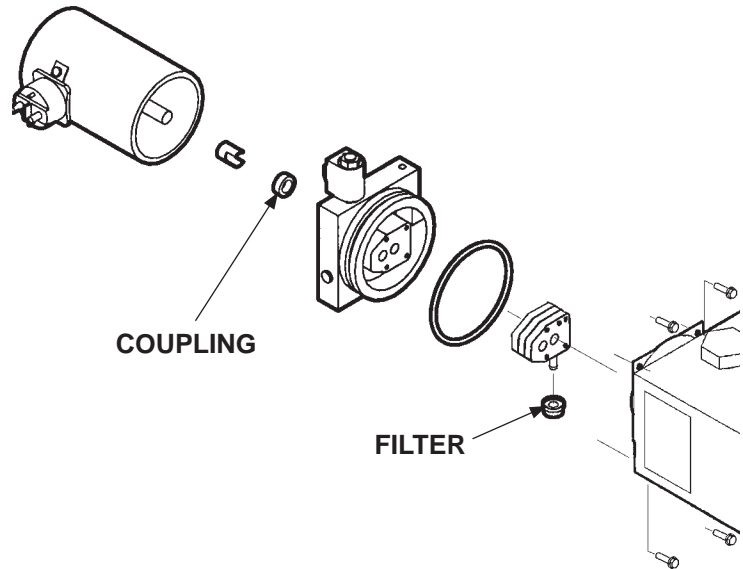

FIG. 30-1

CHECKING SOLENOID SWITCH

1. Verify that power is being supplied to solenoid terminal "A". Recharge the battery if less than 12 volts.
2. Touch a jumper wire to terminals "A" & "C". If motor runs, check switch, switch connections, and white wire. Correct the connections or replace the switch.
3. Touch heavy jumper cables to terminals "A" & "B". If motor runs, replace the motor solenoid. If motor **does not** run, repair or replace the pump motor.

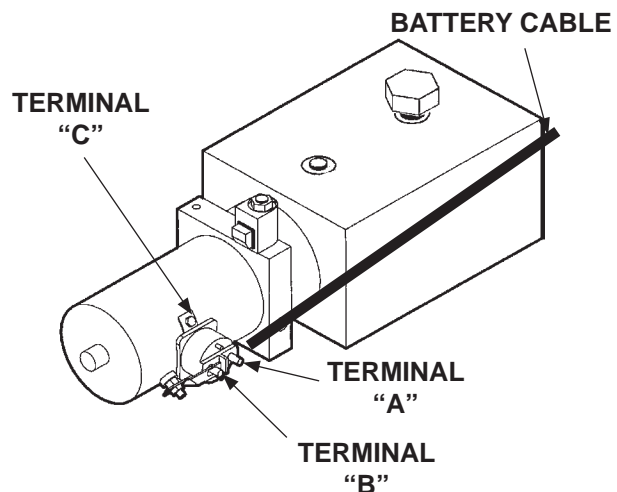

FIG. 30-2

FUSED POWER CABLE

⚠ WARNING
 Do not attach cable to battery until Liftgate is completely installed.

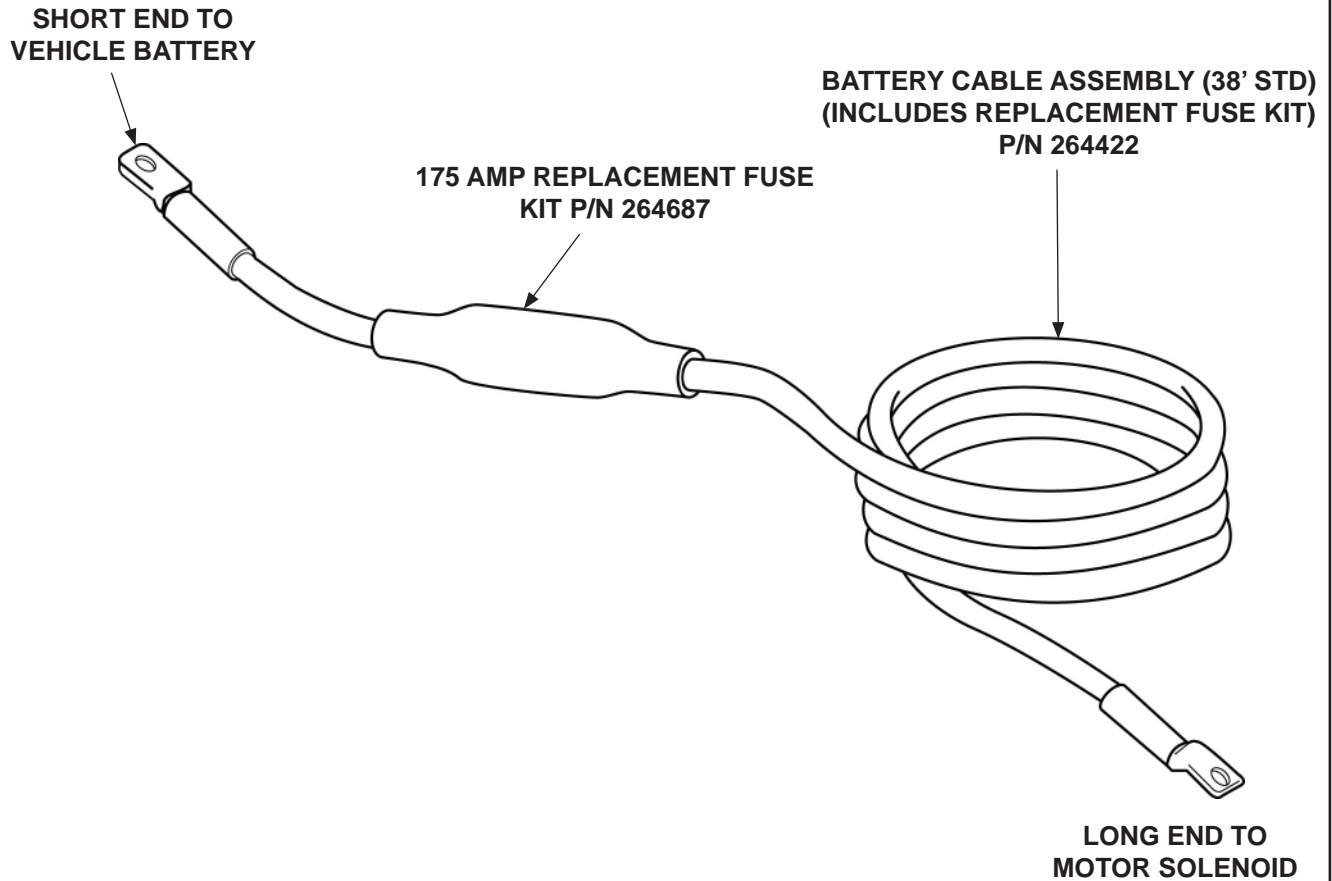



FIG. 31-1

OPTIONAL POWER CABLE KITS		
DESCRIPTION	PART NUMBER	FIGURE
40' CABLE ASSEMBLY (WITH 200 AMP FUSE)	264848	(CABLE ASSEMBLY) 
10' EXTENSION CABLE ASSEMBLY	264849	(EXTENSION CABLE ASSEMBLY) 

MAXON[®] 11921 Slauson Ave. Santa Fe Springs, CA. 90670 (800) 227-4116 FAX (888) 771-7713

WIRING TO PUMP MOTOR

NOTE: MAXON recommends using dielectric grease on all electrical connections.

1. Monthly, check wiring from the motor solenoid on the pump to the Liftgate/vehicle battery.

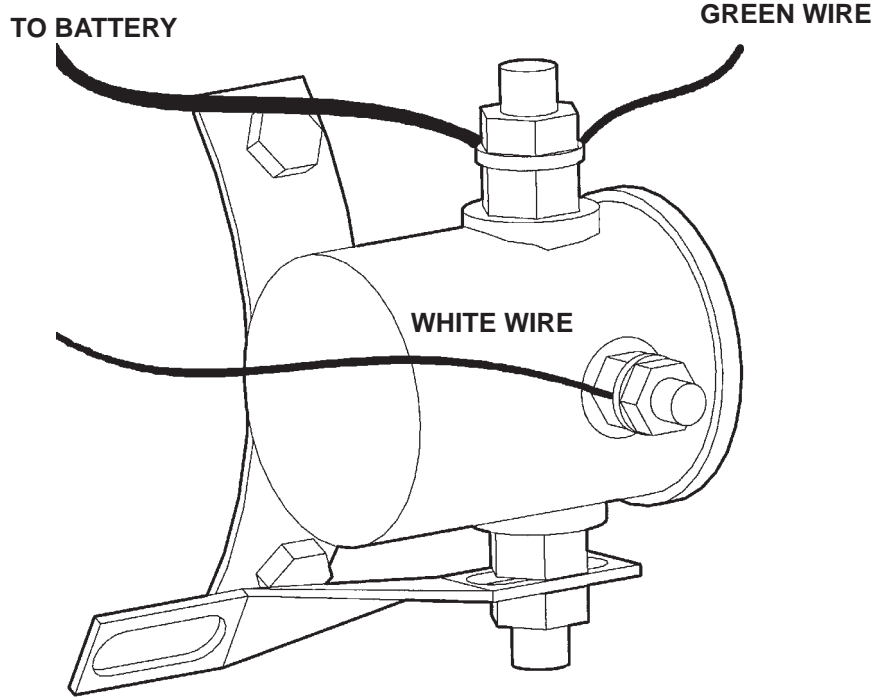

OLD STYLE MOTOR SOLENOID
FIG. 32-1

2. To prevent the Liftgate from malfunctioning, ensure cable/wiring connections are clean and tight. .

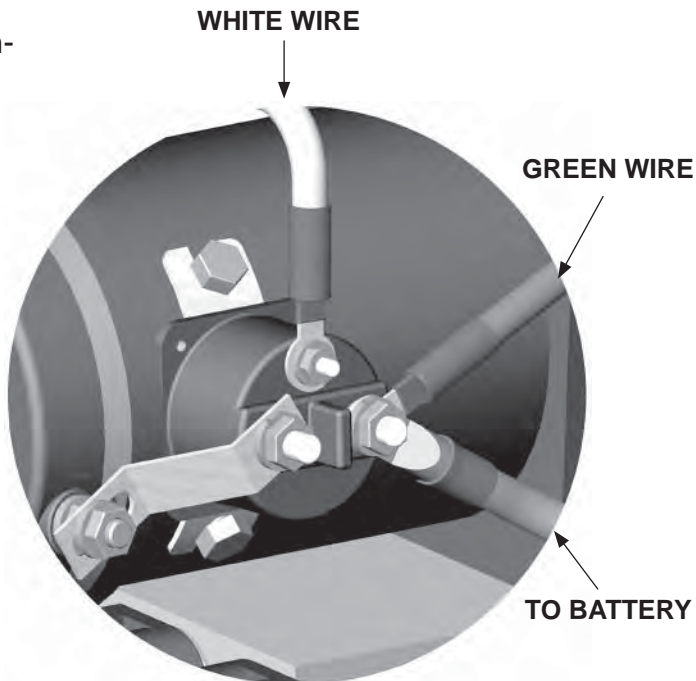

NEW STYLE MOTOR SOLENOID
FIG. 32-2

PUMP WIRING FOR CAM TYPE CLOSER

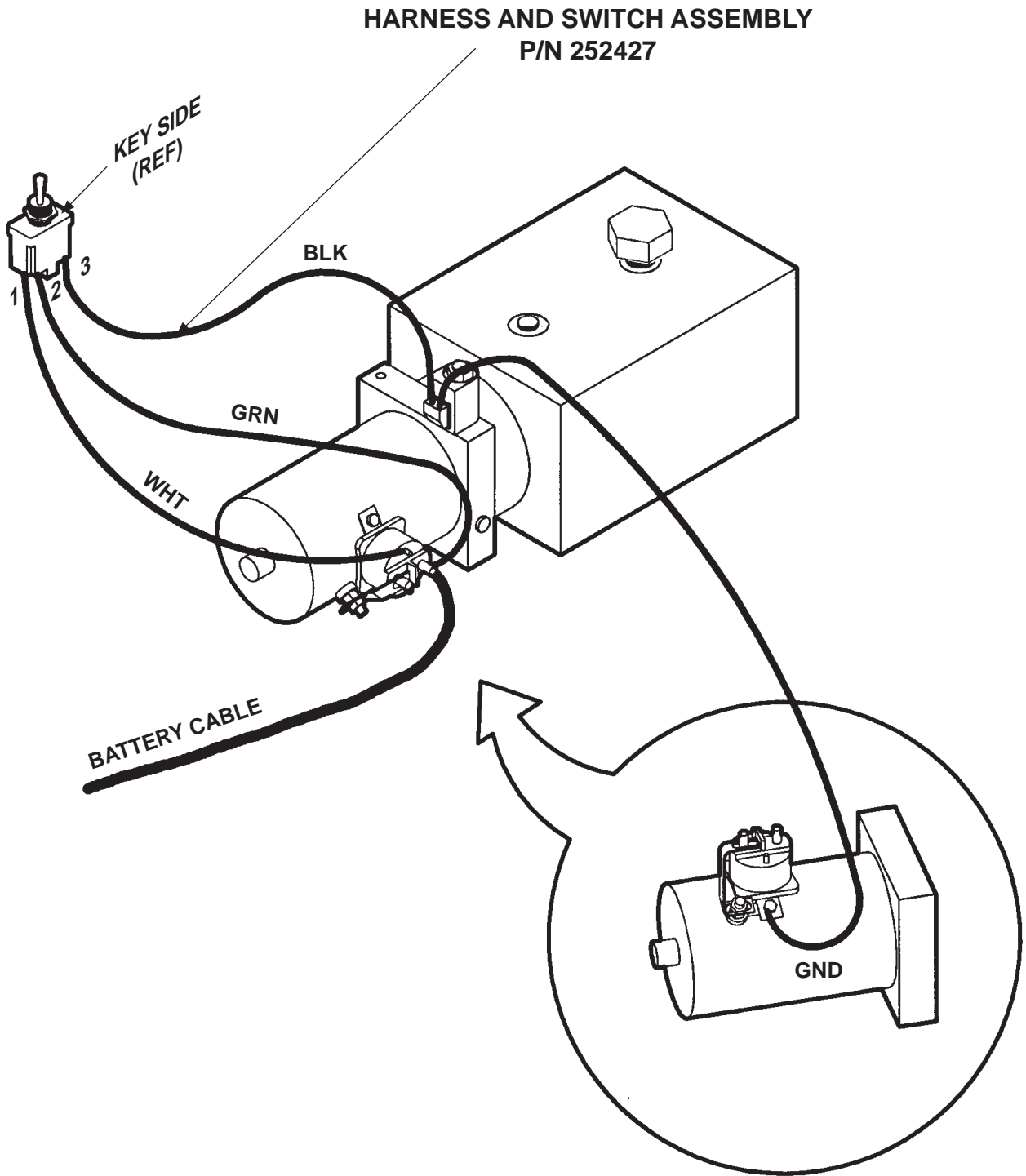

FIG. 33-1

PUMP WIRING FOR HYDRAULIC CLOSER

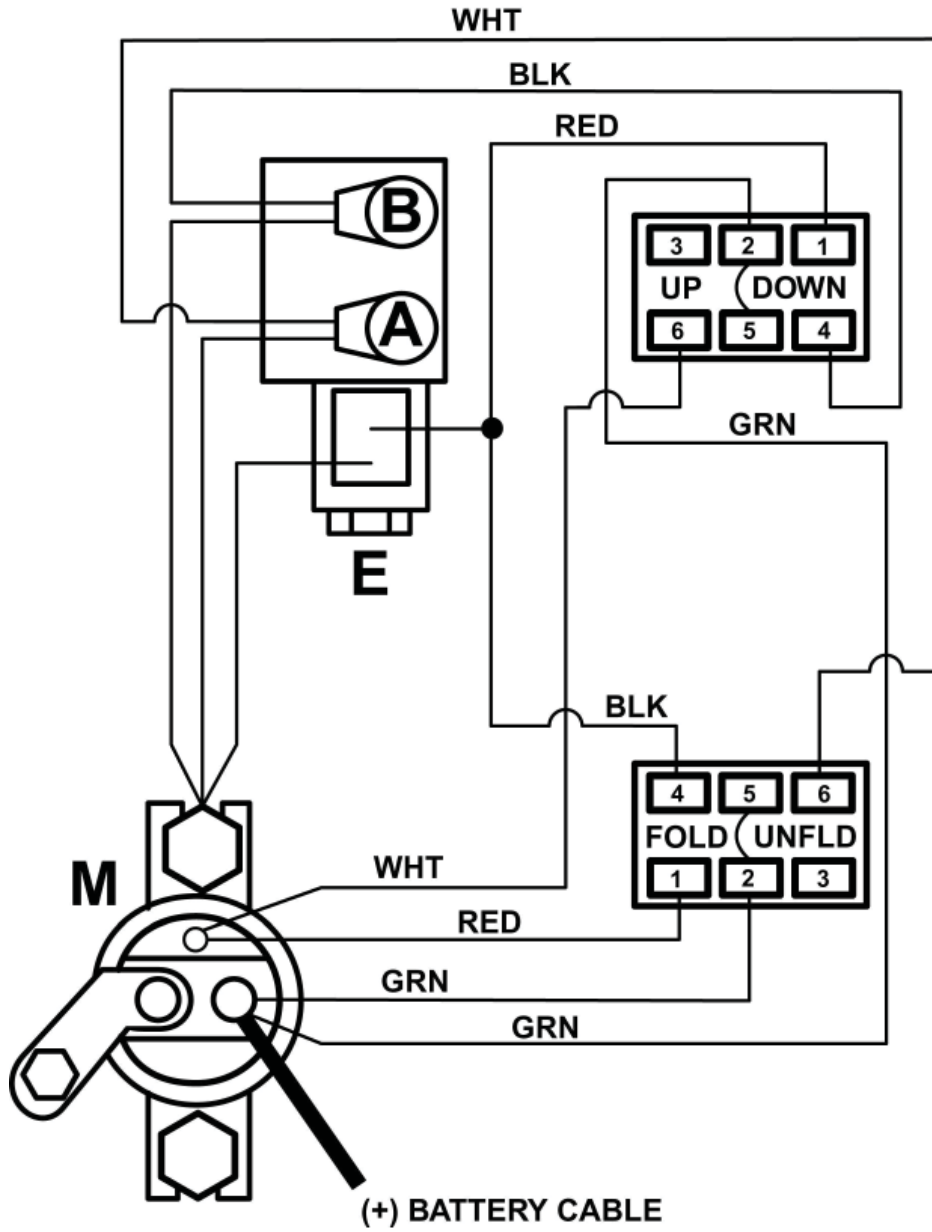

FIG. 34-1

MAXON

11921 Slauson Ave. Santa Fe Springs, CA. 90670 (800) 227-4116 FAX (888) 771-7713

WIRE ROPE SCHEMATIC

NOTE: As cylinder shaft retracts (indicated by large arrow), the wire ropes move in the direction indicated by small arrows. The runners and platform will rise.

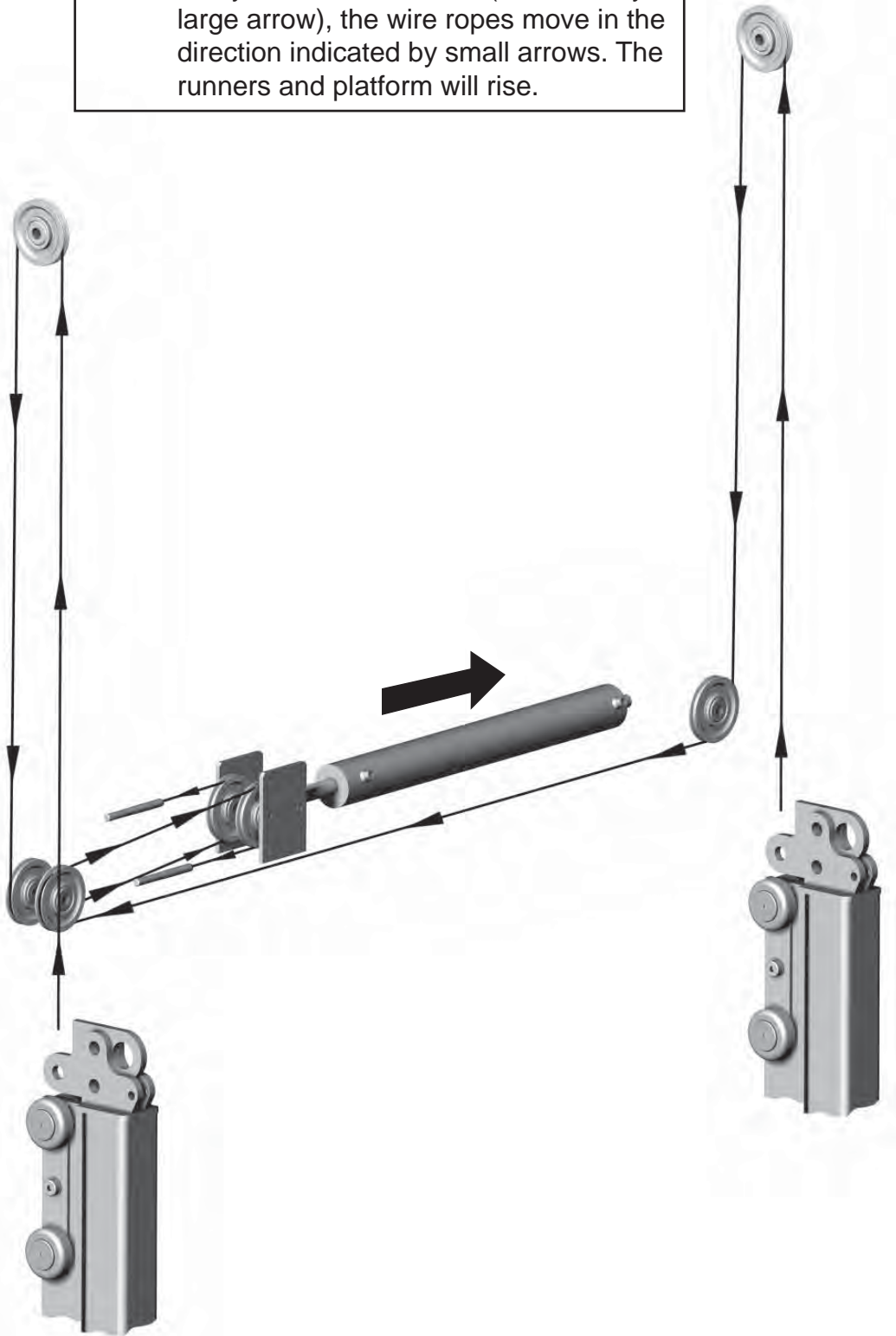

FIG. 35-1

WIRE ROPE MAINTENANCE

NOTE: The most important assemblies in the unit are the wire ropes. These **MUST** be checked **every three months** for broken wires and lack of lubrication, particularly in the areas where the wire ropes pass around the sheaves during the up & down movement of the platform.

1. Remove the covers from the tops of the column assemblies and from the main frame. Clean the wire rope area first, then visually inspect the area.

⚠ WARNING

Keep hands away from the unit. Do not check wire ropes when unit is operating.

2. It is necessary to run the platform through several cycles of operation (stopping the unit frequently) to properly inspect the required areas of wire rope. The wire rope is composed of several strands of individual wires (**FIG. 36-1**).
3. Fatigue breaks occur in individual wires. The breaks are square and usually in the crown of the strands (**FIG. 36-2**).

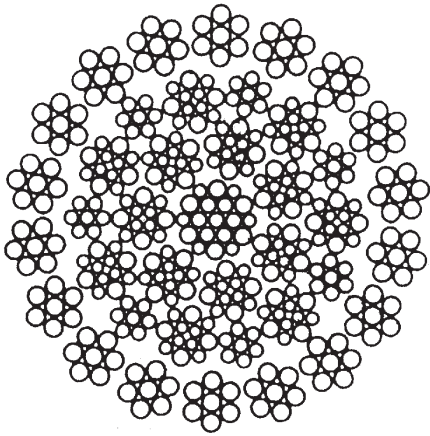

FIG. 36-1



FIG. 36-2

NOTE: The “**WARNING**” plate attached to the R.H. end of the main frame cover details explicit information regarding broken wires.

4. The wire ropes come from the factory internally lubricated. However, if upon inspection the wires look dry, grease with automobile type grease to prolong the life of the wire rope.
5. If 6 or more wires are broken 2-1/2” or more in length of wire rope, the wire rope must be replaced. See **WIRE ROPE REPLACEMENT**.

ADJUSTMENTS

WIRE ROPE ADJUSTMENT (NEW ROPES)

- Using curbside control switch, raise platform until it is almost level with the top surface of the main frame assembly.

⚠ WARNING
Do not allow runners to hit stops.

- Release toggle switch. Check that the platform is level. Platform can be lowered when performing this adjustment. See illustrations.

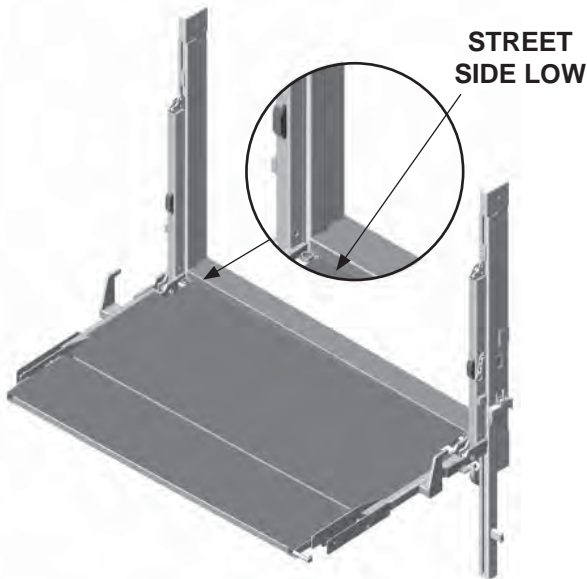

FIG. 37-1

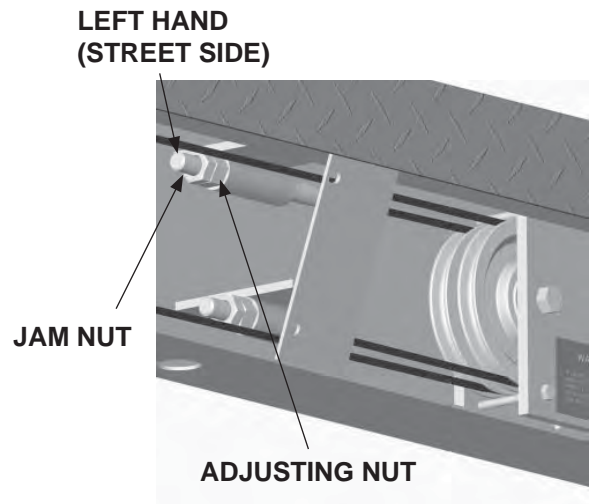

FIG. 37-2

- If platform is not level, adjust wire rope. To adjust top wire rope and bottom wire rope, run adjusting nut against tube until platform is level.

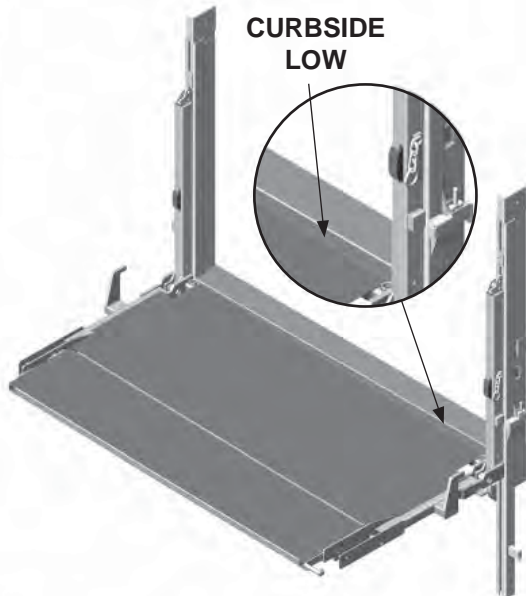

FIG. 37-3

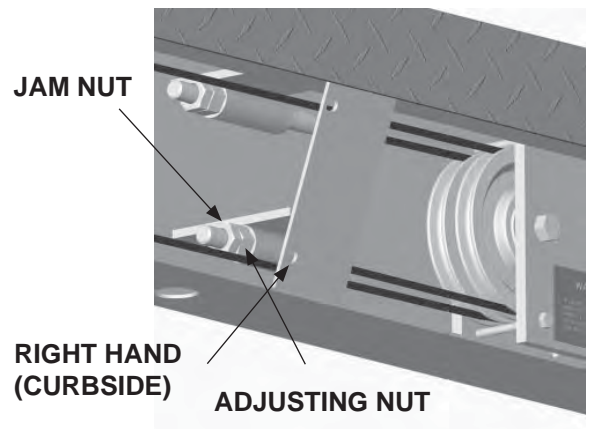

FIG. 37-4

WIRE ROPE ADJUSTMENT (NEW ROPES) - Continued

4. Using curbside switch, raise platform until tops of runners are about 1/4" from the stops in the column assemblies. Release toggle switch. **Do not allow the tops of runners to hit stops. There must be a gap.**
5. Check the amount of cylinder shaft extending from the barrel. There should be 1-1/8" minimum. Both wire ropes will require equal adjustment for this dimension.
6. Run platform up to main frame assembly and check that platform remains level. Adjust if necessary.

NOTE: The following adjustment allows the curbside runner to hit the stop 1/2" before the street side runner. This adjustment is made on the "LOWER" wire rope fitting (right hand, curbside wire rope).

7. Tighten the adjusting nut against the tube approximately 6-8 turns. Raise platform. As soon as the curbside runner touches the stop, release the switch. Check the distance between the top of the street side runner and the street side stop. If the measurement is 1/2", the adjustment is correct. If it is not, lower the platform and adjust the "LOWER" wire rope again. Raise platform and release switch when curbside runner touches the stop. Check measurement between top of street side runner and the stop. This adjustment will probably have to be performed two or three times to obtain the 1/2" dimension.

NOTE: During this adjustment, the platform may tend to ride slightly out of level. This is temporary. After unit is tested and operates with loads on platform, the unit will correct itself.

8. When adjustment is correct, lower platform, tighten stop plate and jam nut against adjusting nut on both wire rope fittings.
9. Replace all covers. Center a load (approximately 500 lb.) on the platform.
10. Cycle load up and down approximately 20 times to seat the the wire ropes.
11. Adjustment is complete and Liftgate is ready for use.

WIRE ROPE ADJUSTMENT

NOTE: Under normal operating conditions (using the unit to its rated capacity), the wire ropes do not require adjustment at the 3 month inspection period. However, it is recommended that the unit be checked at this time.

1. Remove the cover from the main frame assembly.
2. Using the curbside remote control switch, raise the platform. Watch the tops of right and left hand side runners of the unit. Both runners should strike the stops in the column assemblies at the same time. Release the toggle switch.
3. In the main frame assembly, check the amount of rod extending from cylinder barrel. There should be 1" (or more) showing. Under these conditions, the wire ropes **do not** require adjustment.

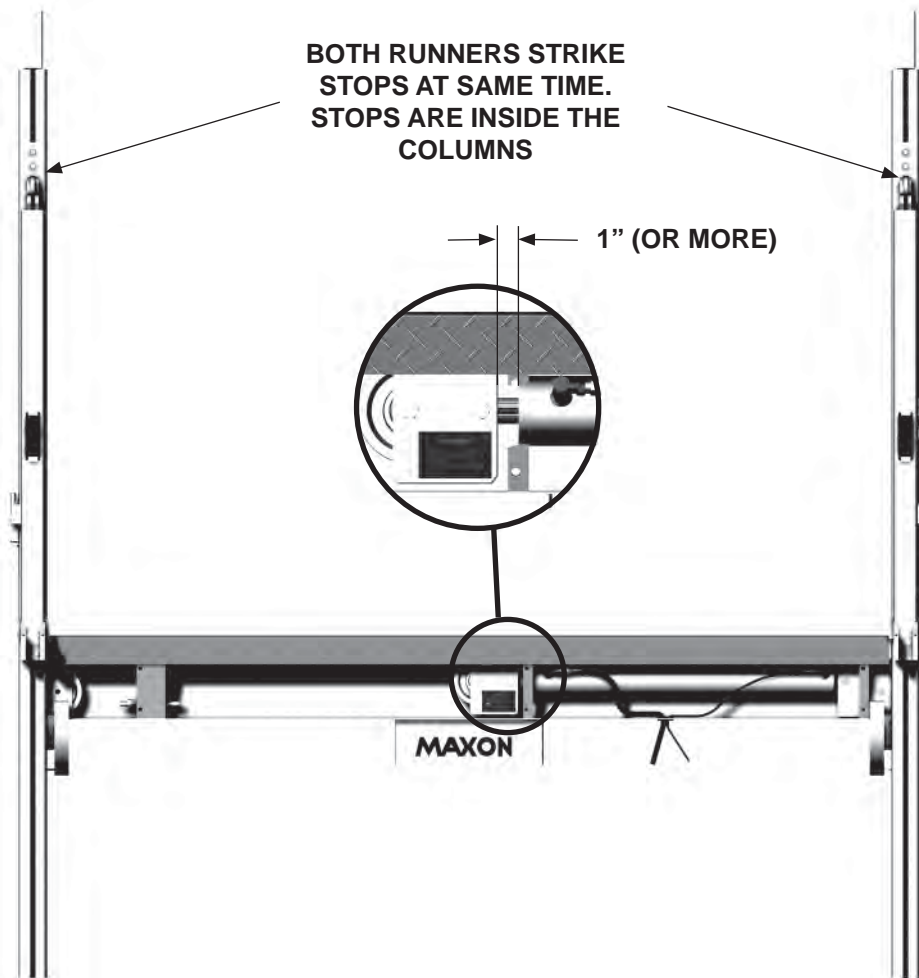
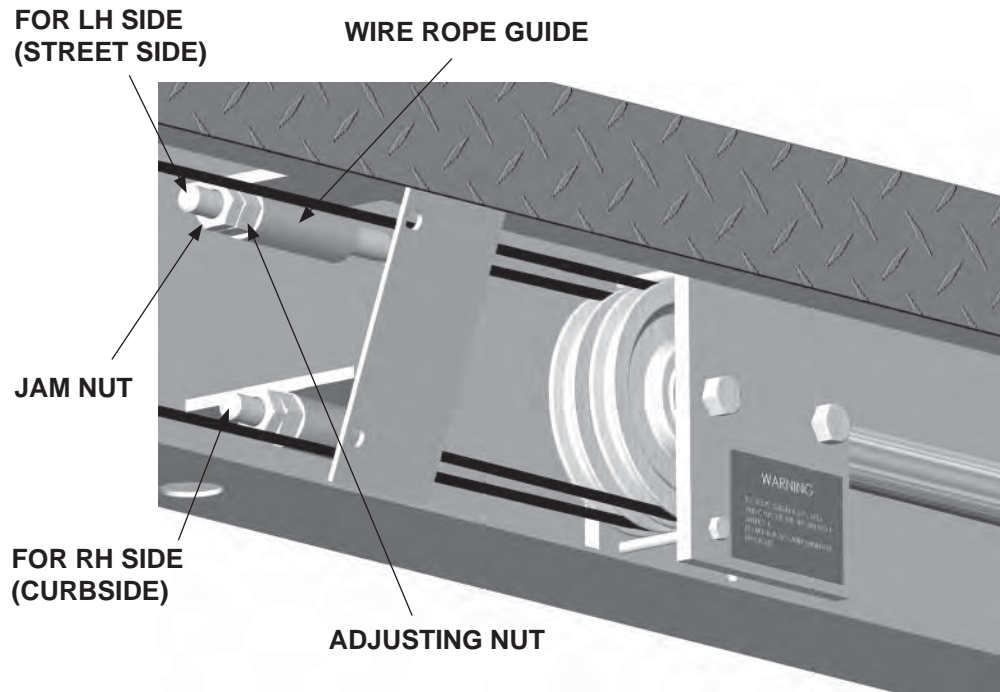

FIG. 39-1

4. If one runner strikes the stop and the other does not, the wire rope has stretched on the runner (and does not strike the stop) or the cylinder rod has bottomed out in the barrel.
5. Measure the gap between the runner and stop. Adjust per instructions on the next page.

6. Lower platform to the ground.
7. If the **left hand** runner is not touching the stop, the **left hand** wire rope needs to be adjusted.
8. If the **right hand** runner is not touching the stop, the **right hand** wire rope needs to be adjusted.



**LEFT HAND WIRE ROPE ADJUSTMENT
FIG. 40-1**

NOTE: The left hand (street side) adjustment is shown. If the right hand (curbside) wire rope is adjusted, the lower wire rope fitting (RH side) needs to be adjusted.

9. Loosen the jam nut. With a wrench, screw adjusting nut clockwise to pull wire rope fitting through the guide. For example, if the gap between runner and stop is 3/8", adjust nut against guide until 3/8" of wire rope fitting is pulled through the guide.
10. It may not be possible to obtain the correct adjustment the first time. Operate the unit and check the runners. If both runners touch the stops at the same time and 1" of cylinder rod is visible from the barrel, adjustment is correct. If not, lower platform to ground and adjust accordingly on nut. Operate unit and recheck. When adjustment is correct, tighten jam nut.

CAM FOLLOWER ADJUSTMENT

NOTE: The cam follower should not be adjusted to the point where the chain engages loosely. A 1/8" gap from chain to pin is sufficient.

1. Rotate the platform closer handle clockwise until the cam followers are against adjustment bolts.
2. Raise the platform until one of the cam follower arms is touching the adjustment bolt.
3. Unscrew the opposite side adjustment bolt until it touches the cam follower arm.
4. Continue to raise the platform until it reaches up-stops. Engage the platform retention chain.
5. If the chain can not engage, unscrew both cam follower adjustment bolts a little more.
6. Repeat steps 4 and 5 until the chain is engaged.
7. Open the platform and bend the keeper plate against the flat edge of the bolts.

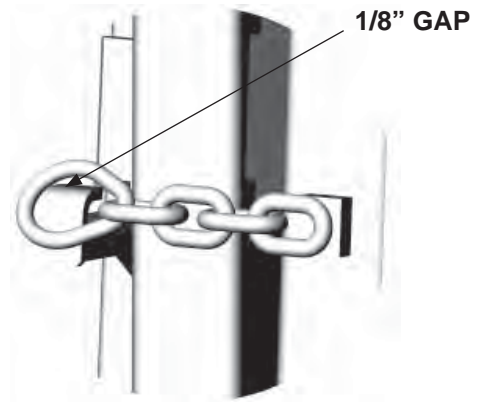

FIG. 41-1

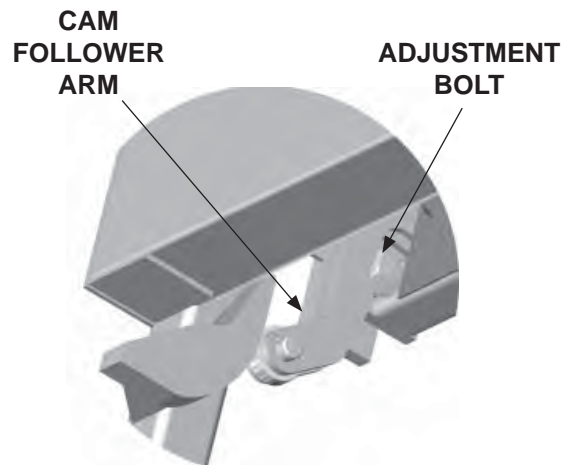

FIG. 41-2

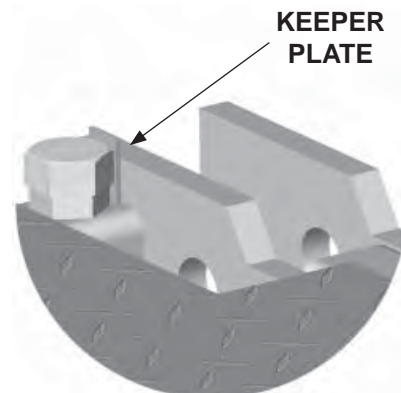

FIG. 41-3

PUMP PRESSURE SETTING ADJUSTMENT

1. Lower the platform to the ground to relieve any pressure on the hoses. Remove the existing hose and swivel assembly from port "B" (3/8 NPT).
2. Install a **0-3000 PSI Gauge (Item 1)** to port "B". Remove the valve cap (**Item 2**) from the pump block (**Item 3**).
3. Using the **RAISE/LOWER** switch on the curbside of the vehicle, raise the unit and check the gauge reading. Adjust the relief valve to a pressure setting of **2750 PSI**.
4. Activate the **RAISE/LOWER** switch several times to verify that the pressure shown on the gauge remains at the proper setting (**FIG. 42-1**).

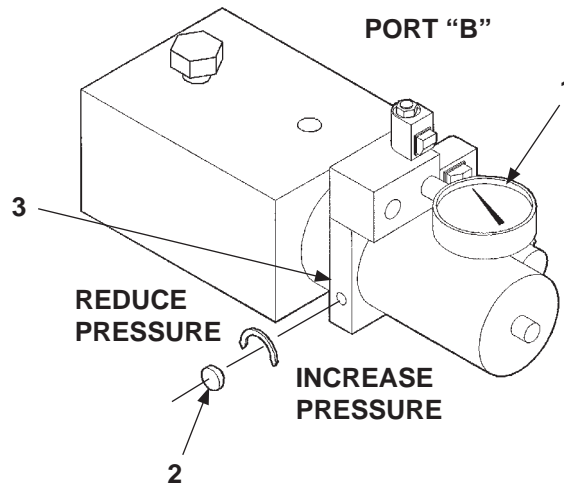

FIG. 42-1

⚠ WARNING
Setting the pressure higher than recommended could enable the Liftgate to raise loads in excess of its rated capacity.

5. If the unit does not maintain the pressure reading, it may be necessary to remove and inspect the relief valve components (**FIG. 42-2**). Check for nicks or cuts on the spring (**Item 4**) and ball (**Item 5**). Replace any damaged parts before reassembling the unit.
6. To seat the ball upon reassembly, insert a 3/16" diameter rod through the spring and tap the ball against the seat with a hammer.

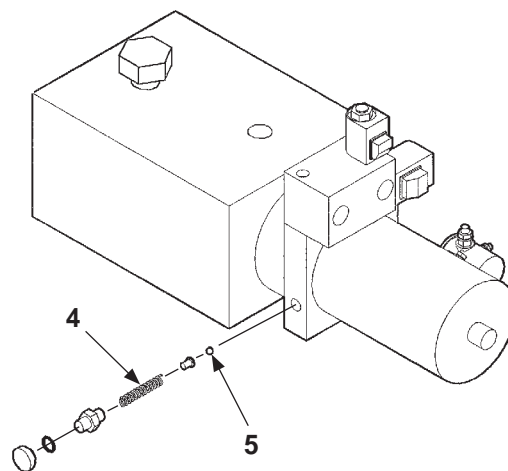

FIG. 42-2

THIS PAGE INTENTIONALLY LEFT BLANK

3 POINT CHAIN INSPECTION

NOTE: It is necessary to perform the following inspection to ensure RC Liftgate is operating correctly. If any of the inspections and/or corrections are not performed, chain assembly may get caught and prevent Liftgate from operating.

1. Unfold the platform about 10" from the stowed position (FIG. 44-1). Then, make sure both **chain stops** (FIG. 44-1A) are in place and both **chains** (FIG. 44-1) are not twisted. Next, make sure **chain covers** are positioned correctly (FIG. 44-1) and bolted to **chain** with fasteners shown in FIG. 45-1B.
2. If the **chains** are twisted or if **chain covers** are incorrectly positioned, unfold and lower platform to the ground. Unbolt upper end of chain from runner as shown in FIG. 45-1C. Untwist chain until every other link is in a straight line and refasten.
3. If **chain cover** is not positioned correctly (FIG. 44-1), measure length of flipover ("A") (FIG. 45-1A). Next, measure distance ("B") from center of **folding section pin** to center of **flipover hinge bolt** (FIG. 45-1D). After measuring "A" & "B", find correct "L" position for **chain covers** in TABLE 1 on the next page. Bolt the chain cover to chain (FIG. 45-1B).
4. Raise and fold platform about 10" from the stowed position (FIG. 44-1). Check for correct position of **chain cover** (FIG. 44-1). If both **chain covers** are positioned correctly, the procedure is complete. If position is incorrect for **chain cover** on either side, go to **step 5**.
5. Mark the chain where the end of **chain cover** should be (FIG. 44-1). Open the platform. Unbolt the chain cover (FIG. 45-1B). Move the chain cover to the mark on the chain (FIG. 44-1). Bolt the chain cover (FIG. 45-1B) into correct position. Repeat **step 4**.

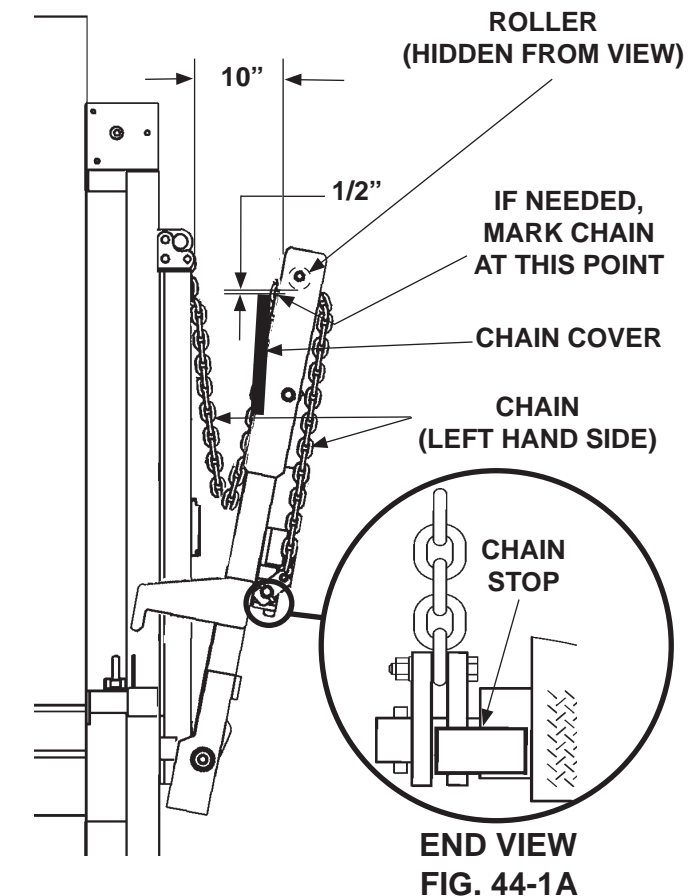

CHAINS ON TYPICAL RC-SERIES LIFT-GATE (LEFT HAND SIDE SHOWN)
FIG. 44-1

Contact MAXON for replacement parts. All attaching hardware is Grade 8 quality.

MAXON

11921 Slauson Ave. Santa Fe Springs, CA. 90670 (800) 227-4116 FAX (888) 771-7713

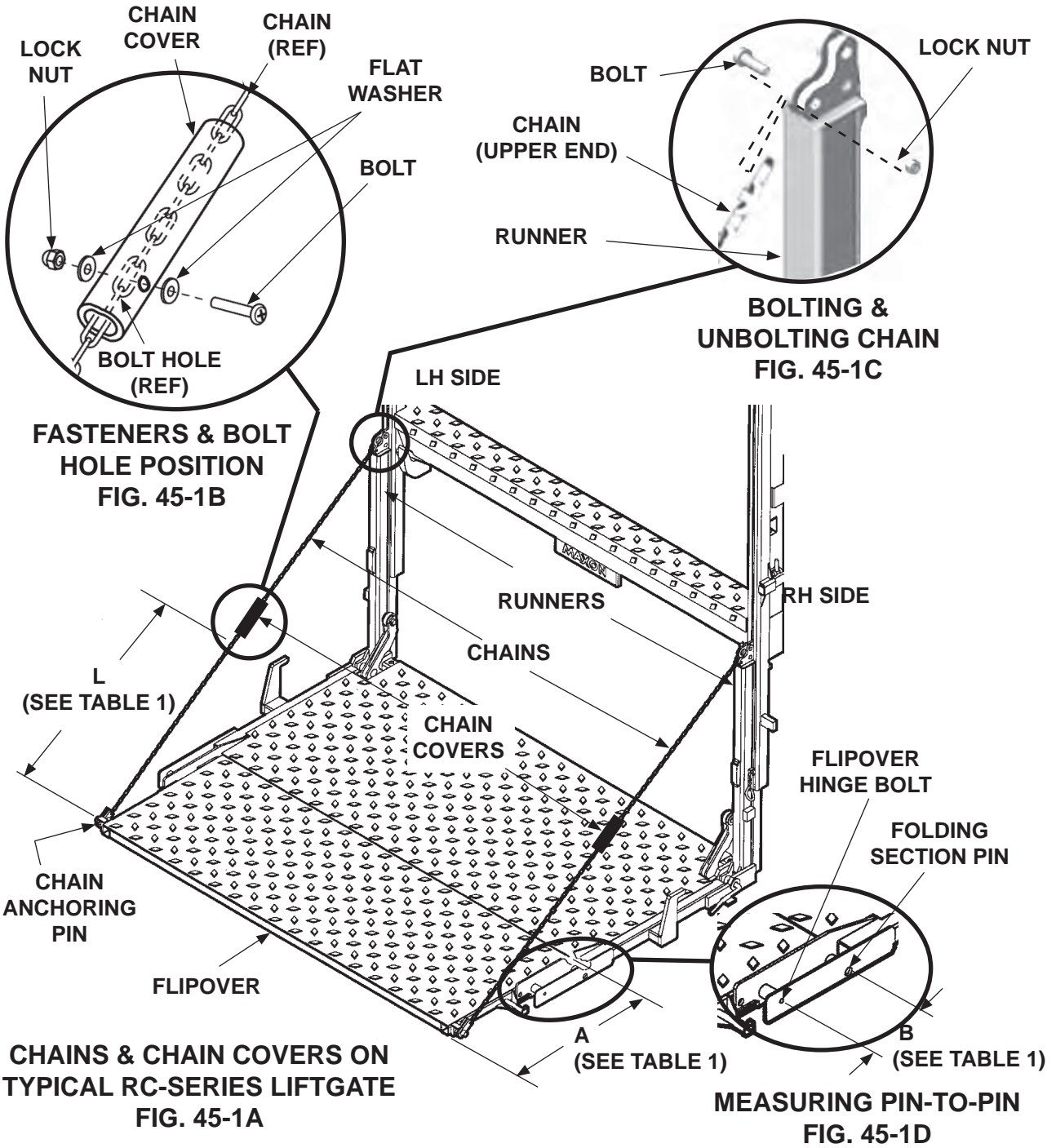

IF FLIPOVER LENGTH "A" =	18"	18"	24"	24"	30"	30"	36"	36"	42"	42"
& PIN-TO-PIN LENGTH "B" =	10"	14"	10"	14"	10"	14"	10"	14"	10"	14"
CHAIN COVER POSITION IS = "L"	31"	35"	37"	41"	43"	47"	49"	53"	55"	59"

TABLE 1

PARTS BREAKDOWN

MAIN ASSEMBLY-1

MAXON[®]

11921 Slauson Ave. Santa Fe Springs, CA. 90670 (800) 227-4116 FAX (888) 771-7713

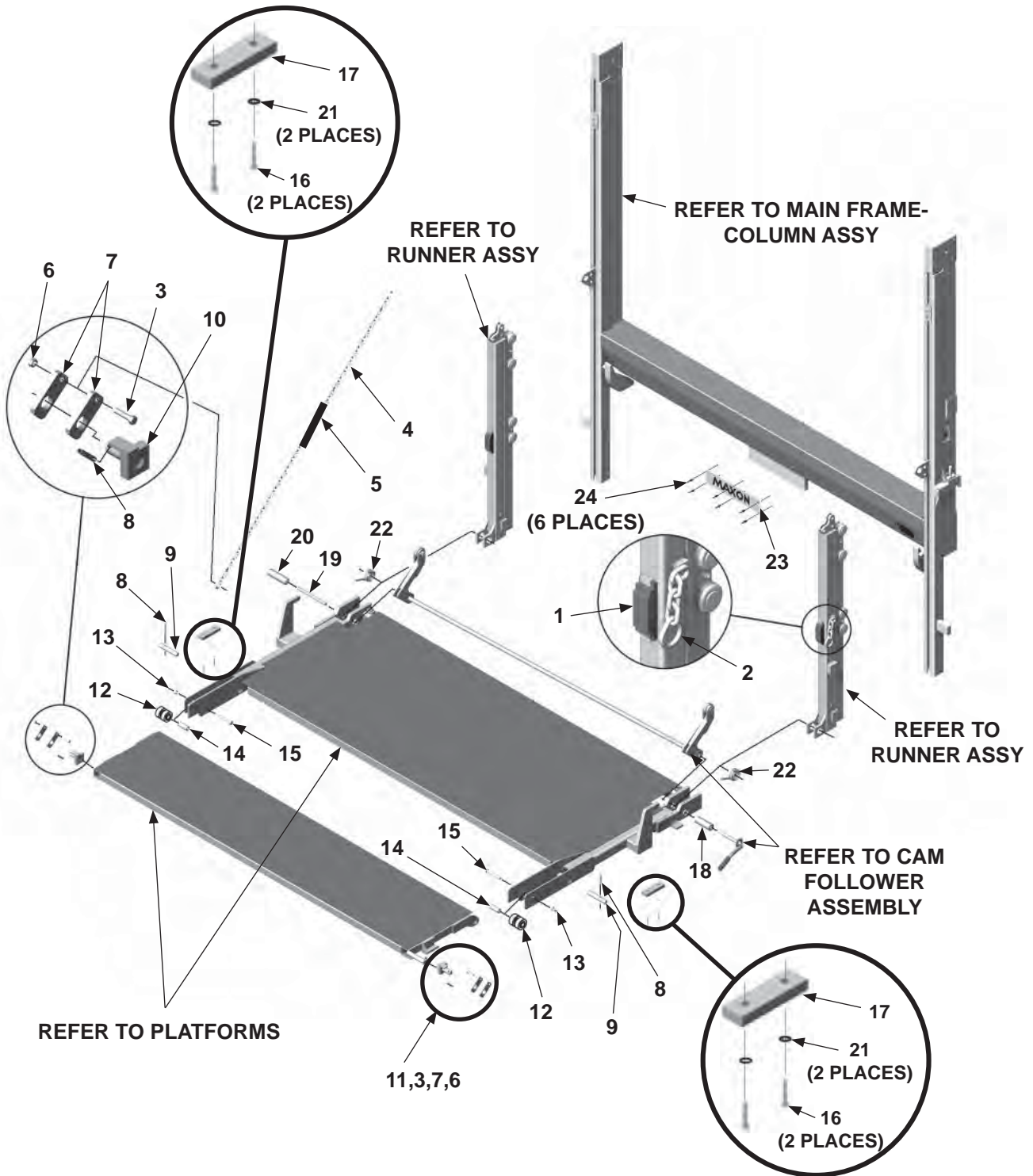

ITEM	QTY.	PART NO.	DESCRIPTION
1	2	227426	RUBBER BUMPER
2	1	250784	PLATFORM RETAINER (1 PC. PLATFORM)
		252452	PLATFORM RETAINER (2 PC. PLATFORM)
3	4	030041	BOLT, 3/8"-24 X 1-1/2" LG.
4	2	(SEE CHAIN CHART)	CHAIN
5	2	202840	HOSE, CHAIN
6	4	203853	LOCK NUT, 3/8"-24
7	4	202671	RUNNER LINK, 3-3/8" LG.
8	5	221416	ROLL PIN, 3/8" X 2" LG.
9	2	251859	PIN, FOLDING SECTION
10	1	222210-01	BRACKET, CHAIN ANCHOR (LH)
11	1	222210-02	BRACKET, CHAIN ANCHOR (RH)
12	2	280594-01	ROLLER, NYLON
13	2	901016-1	LOCK NUT, THIN HEAD, 1/2"-20
14	2	280596-01	BUSHING
15	2	202466	BOLT, 1/2"-20 X 3-5/8" LG.
16	4	225279	HEX HEAD SCREW, 1/4"-14 X 1-1/2" LG.
17	2	225278-02	RUBBER BUMPER
18	1	253343	PIN, PLATFORM HINGE
19	1	221905	PIN, CAM FOLLOWER 7-3/4" LG.
20	1	221931	PIN, HINGE 1-1/2" X 4-7/8" LG.
21	4	902013-09	FLAT WASHER, 1/4"
22	2	202527	TORSION SPRING
23	1	050175	MAXON PLATE, 3.25"W X 15" LG.
24	6	207644	POP RIVET, 3/16" DIA. X .58" LG.

CHAIN CHART

	42" PLATFORM	48" PLATFORM	54" PLATFORM	60" PLATFORM	66" PLATFORM	72" PLATFORM	78" PLATFORM	84" PLATFORM	96" PLATFORM
RC-2B, 3B	202698-01 60" CHAIN	202698-02 64" CHAIN	202698-03 68" CHAIN	202698-04 72" CHAIN	202698-05 77" CHAIN	202698-06 82" CHAIN			
RC-4B	202698-07 65" CHAIN	202698-08 69" CHAIN	202698-09 73" CHAIN	202698-05 77" CHAIN	202698-06 82" CHAIN	202698-10 86" CHAIN			
RC-5B				202698-11 84" CHAIN	202698-12 88" CHAIN	202698-13 92" CHAIN	202698-14 97" CHAIN	202698-15 102" CHAIN	202698-16 112" CHAIN
RC-6B							202698-17 104" CHAIN	202698-18 108" CHAIN	202698-19 118" CHAIN

MAXON 11921 Slauson Ave. Santa Fe Springs, CA. 90670 (800) 227-4116 FAX (888) 771-7713

MAIN FRAME-COLUMN ASSEMBLY-1

MAXON[®] 11921 Slauson Ave. Santa Fe Springs, CA. 90670 (800) 227-4116 FAX (888) 771-7713

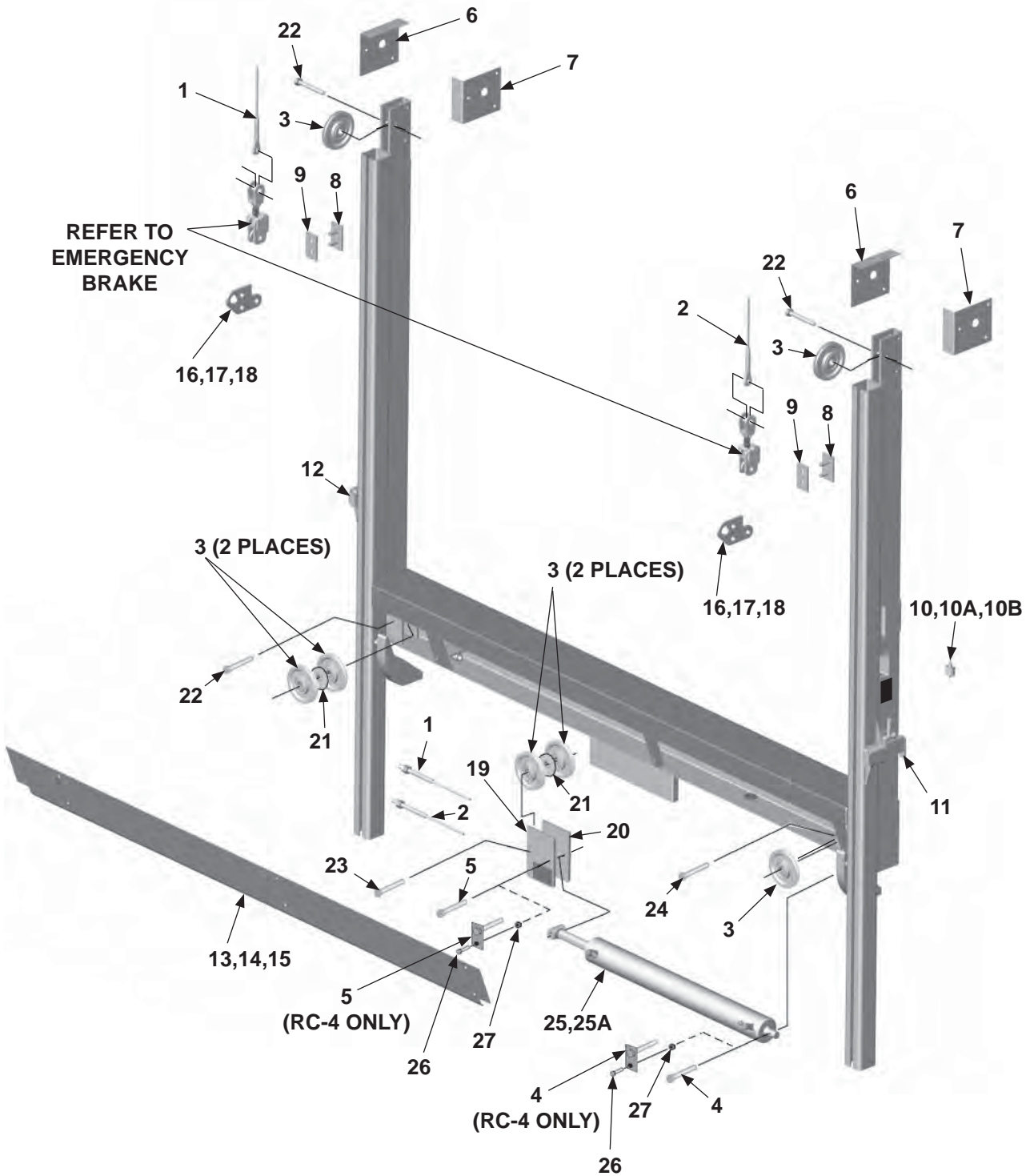

ITEM	QTY.	PART NO.	DESCRIPTION
REF	1	250908	MAIN FRAME COLUMN ASSY, 96" WIDE
		250908-04	MAIN FRAME COLUMN ASSY, 102" WIDE
1	1	227191-01	WIRE ROPE ASSY. 96" WIDE (RC-2,RC-3)
		227192-01	WIRE ROPE ASSY. 102" WIDE (RC-2,RC-3)
		251588-01	WIRE ROPE ASSY. 96" WIDE (RC-4)
		227190-01	WIRE ROPE ASSY. 102" WIDE (RC-4)
		252402-01	WIRE ROPE ASSY. 96" WIDE (RC-5,RC-6)
		252403-01	WIRE ROPE ASSY. 102" WIDE (RC-5,RC-6)
		252401-01	WIRE ROPE ASSY. 96" WIDE (RC-6K)
		252400-01	WIRE ROPE ASSY. 102" WIDE (RC-6K)
2	1	227191-02	WIRE ROPE ASSY. 96" WIDE (RC-2,RC-3)
		227192-02	WIRE ROPE ASSY. 102" WIDE (RC-2,RC-3)
		251588-02	WIRE ROPE ASSY. 96" WIDE (RC-4)
		227190-02	WIRE ROPE ASSY. 102" WIDE (RC-4)
		252402-02	WIRE ROPE ASSY. 96" WIDE (RC-5,RC-6)
		252403-02	WIRE ROPE ASSY. 102" WIDE (RC-5,RC-6)
		252401-02	WIRE ROPE ASSY. 96" WIDE (RC-6K)
		252400-02	WIRE ROPE ASSY. 102" WIDE (RC-6K)
3	7	253307	SHEAVE ASSY. W/BEARING (RC-2,RC-3)
		253308	SHEAVE ASSY. W/BEARING (RC-4)
		253309	SHEAVE ASSY. W/BEARING (RC-5,RC-6,RC-6K)
3A	1	253108	SHEAVE (RC-2,RC-3)
	1	253107	SHEAVE (RC-4)
	1	253106	SHEAVE (RC-5,RC-6,RC-6K)
3B	1	801412	BEARING
4	1	202465	BOLT, 1/2"-20 X 2-5/8" LG, GR8 (CYL BOLT: RC-2,RC-3)
		268407-01	PIN WELDMENT, 5/8" X 3-1/2" LG. (RC-4 CYL END ONLY)
		203237	BOLT, 3/4"-16 X 4-15/16" LG, GR5 (CYL BOLT: RC-5,RC-6,RC-6K)
5	1	202466	BOLT, 1/2"-20 X 3-5/8" LG, GR8 (CYL BOLT: RC-2,RC-3)
		268407-02	PIN WELDMENT, 5/8" X 4" LG. (RC-4 ROD END ONLY)
		203236	BOLT, 3/4"-16 X 3-1/4" LG, GR5 (CYL BOLT: RC-5,RC-6,RC-6K)
6	2	202619	COVER, UPPER PULLEY LH, (RC-2,RC-3)
		202927	COVER, UPPER PULLEY LH, (RC-4)
		203212	COVER, UPPER PULLEY LH, (RC-5,RC-6,RC-6K)

MAXON[®] 11921 Slauson Ave. Santa Fe Springs, CA. 90670 (800) 227-4116 FAX (888) 771-7713

MAIN FRAME-COLUMN ASSEMBLY-2

MAXON[®] 11921 Slauson Ave. Santa Fe Springs, CA. 90670 (800) 227-4116 FAX (888) 771-7713

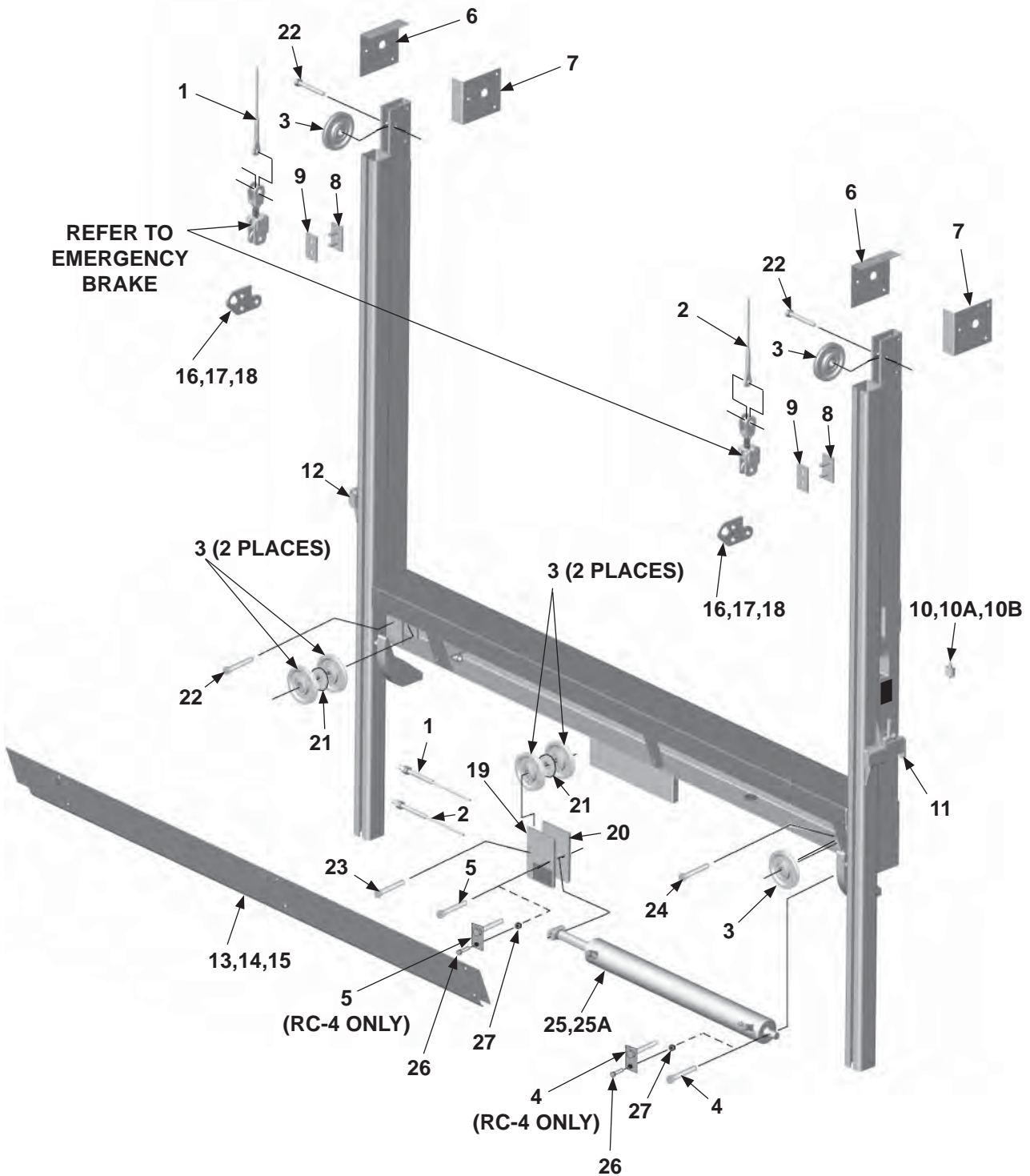

ITEM	QTY.	PART NO.	DESCRIPTION
7	2	202777	COVER, UPPER PULLEY RH, (RC-2, RC-3)
		202928	COVER, UPPER PULLEY RH, (RC-4)
		203213	COVER, UPPER PULLEY RH, (RC-5,RC-6,RC-6K)
8	2	250635	INTERNAL STOP, INNER PLATE
9	2	250634	INTERNAL STOP, OUTER PLATE
10	1	250916	ELECTRICAL SWITCH ASSEMBLY
10A	1	226889	TOGGLE SWITCH
10B	1	250876	SWITCH SEAL
11	1	250800	SAFETY LATCH (RH)
12	1	250800-01	SAFETY LATCH (LH)
13	1	226202	COVER, MAIN FRAME 96" WIDE (RC-2,RC-3,RC-4)
		226203	COVER, MAIN FRAME 102" WIDE (RC-2,RC-3,RC-4)
		226088	COVER, MAIN FRAME 96" WIDE (RC-5,RC-6,RC-6K)
		226089	COVER, MAIN FRAME 102" WIDE (RC-5,RC-6,RC-6K)
14	4	030041	BOLT, 3/8"-24 X 1-1/2" LG, GRADE 8
15	4	203853	LOCK NUT, 3/8"-24
16	2	227195	LINK LUG, RUNNER
17	4	030064	BOLT, 5/8"-18 X 2" LG, GRADE 5
18	4	030569	LOCK WASHER, 5/8"
19	1	202562	CYLINDER ANCHOR PLATE (RC-2,RC-3)
		202926	CYLINDER ANCHOR PLATE (RC-4)
		203210	CYLINDER ANCHOR PLATE (RC-5,RC-6,RC-6K)
20	1	252425	ANCHOR PLATE, CYLINDER ROD END (RC-2,RC-3 ONLY)
21	2	253460	WASHER, SPACER (RC-2,RC-3 ONLY)
22	3	253330	BOLT, 1/2"-20 X 2-3/4" LG
23	1	253331	BOLT, 1/2"-20 X 3-5/8" LG.
24	1	253333	BOLT, SPECIAL, 1/2"-20 X 3" LG, GRADE 8
		253334	BOLT, SPECIAL, 1/2"-20 X 4-3/4" LG, GR8 (RC-5,RC-6,RC6K ONLY)
25	1	253338	CYLINDER ASSY, 3" DIA. X 28" STROKE (RC-2,RC-3)
		253339	CYLINDER ASSY, 3-1/2" DIA. X 28" STROKE (RC-4)
		253340	CYLINDER ASSY, 4" DIA. X 28" STROKE (RC-5,RC-6,RC-6K)
25A	1	253464	SEAL KIT, HYD. CYLINDER (RC-2,RC-3)
		253465	SEAL KIT, HYD. CYLINDER (RC-4)
		253466	SEAL KIT, HYD. CYLINDER (RC-5,RC-6,RC-6K)
26	2	900004-3	CAP SCREW, 1/4"-20 X 1" LG, GRADE 8
27	2	901000	LOCK NUT, 1/4"-20

MAXON[®] 11921 Slauson Ave. Santa Fe Springs, CA. 90670 (800) 227-4116 FAX (888) 771-7713

CAM FOLLOWER ASSEMBLY

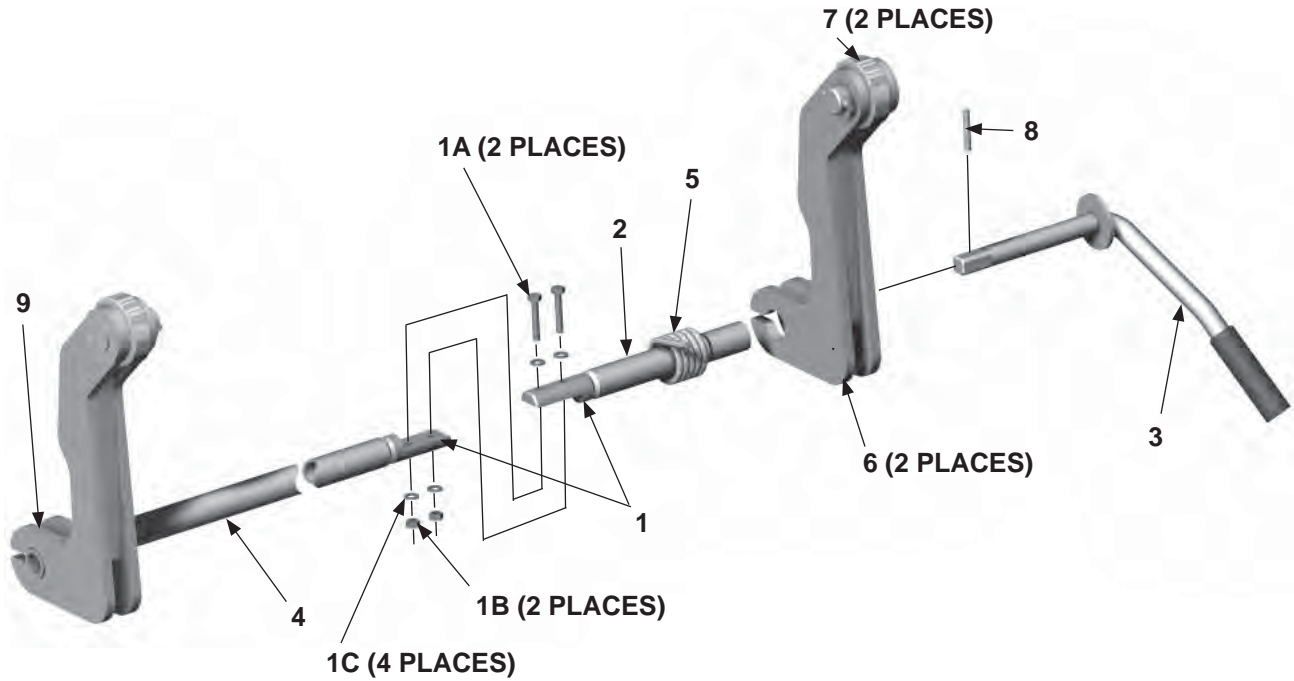

ITEM	QTY.	PART NO.	DESCRIPTION
REF	1	262418	CAM FOLLOWER ASSY. 90" WIDE
		262419	CAM FOLLOWER ASSY. 96" WIDE
		262419-01	CAM FOLLOWER ASSY. 96" WIDE AB
		262420	CAM FOLLOWER ASSY. 102" WIDE
		262420-01	CAM FOLLOWER ASSY. 102" WIDE AB
1	1	262268	COUPLING ASSEMBLY
1A	2	040600	BOLT, 1/4"-20 X 1-1/2" LG
1B	2	030911	LOCK NUT, 1/4"-20
1C	4	030564	FLAT WASHER, 1/4"
2	1	262267	TUBE ANCHOR WELDMENT
3	1	262417	HANDLE WELDMENT, CAM FOLLOWER
4	1	262270	CAM FOLLOWER SHAFT, 96" WIDE
		262270-01	CAM FOLLOWER SHAFT, 102" WIDE
		262270-02	CAM FOLLOWER SHAFT, 90" WIDE
5	1	217643	TORSION SPRING
6	2	251231	CAM WELDMENT
7	2	250844	ROLLER ASSEMBLY
8	1	030410	ROLL PIN, 1/4" X 1-1/2"
9	1	224342	GREASE FITTING

MAXON[®]

11921 Slauson Ave. Santa Fe Springs, CA. 90670 (800) 227-4116 FAX (888) 771-7713

THIS PAGE IS INTENTIONALLY LEFT BLANK

RUNNER ASSEMBLY

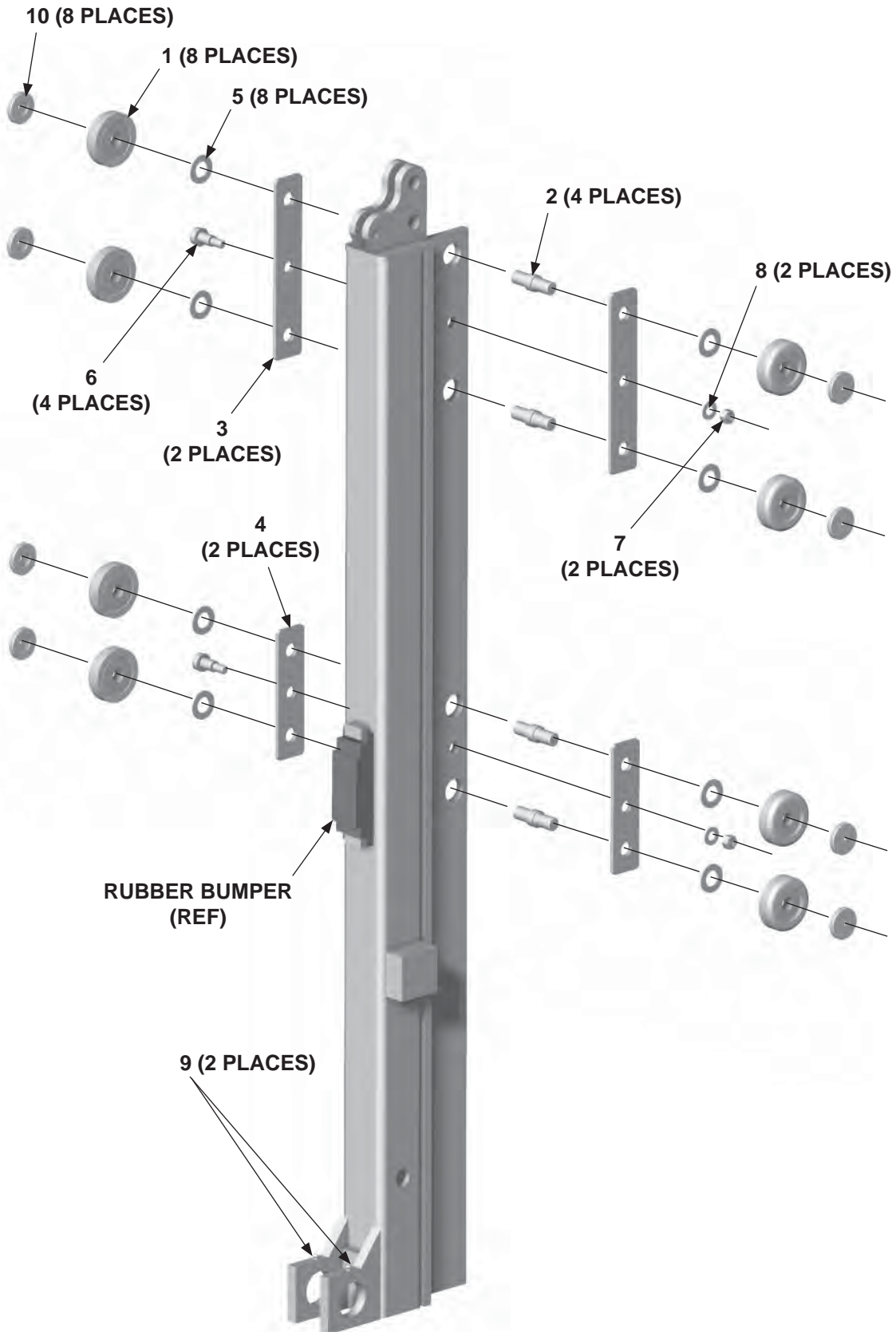

MAXON[®] 11921 Slauson Ave. Santa Fe Springs, CA. 90670 (800) 227-4116 FAX (888) 771-7713

ITEM	QTY.	PART NO.	DESCRIPTION
REF	2	251037-01	RUNNER ASSEMBLY (RC-2,RC-3)
		251038-01	RUNNER ASSEMBLY (RC-4)
		251039-01	RUNNER ASSEMBLY (RC-5,RC-6)
		251040-01	RUNNER ASSEMBLY (RC-6K)
1	8	202800	ROLLER ASSEMBLY (WITH BEARING)
2	4	202796	BALL RACE TANDEM SHAFT
3	2	203002	PLATE, TANDEM SUPPORT, 8" LG. TOP
4	2	227395	PLATE, TANDEM SUPPORT, 8" LG. BOTTOM
5	8	202771	FLAT WASHER, 5/8"
6	2	202797	SHOULDER BOLT, 3/8"-16, 1/2" X 3/4" GRIP
7	2	902001-2	FLAT WASHER, 3/8"
8	2	030955	LOCK NUT, 3/8"-16
9	2	224342	GREASE FITTING
10	8	260057	PLASTIC INSERTS (FOR ROLLERS)

EMERGENCY BRAKE

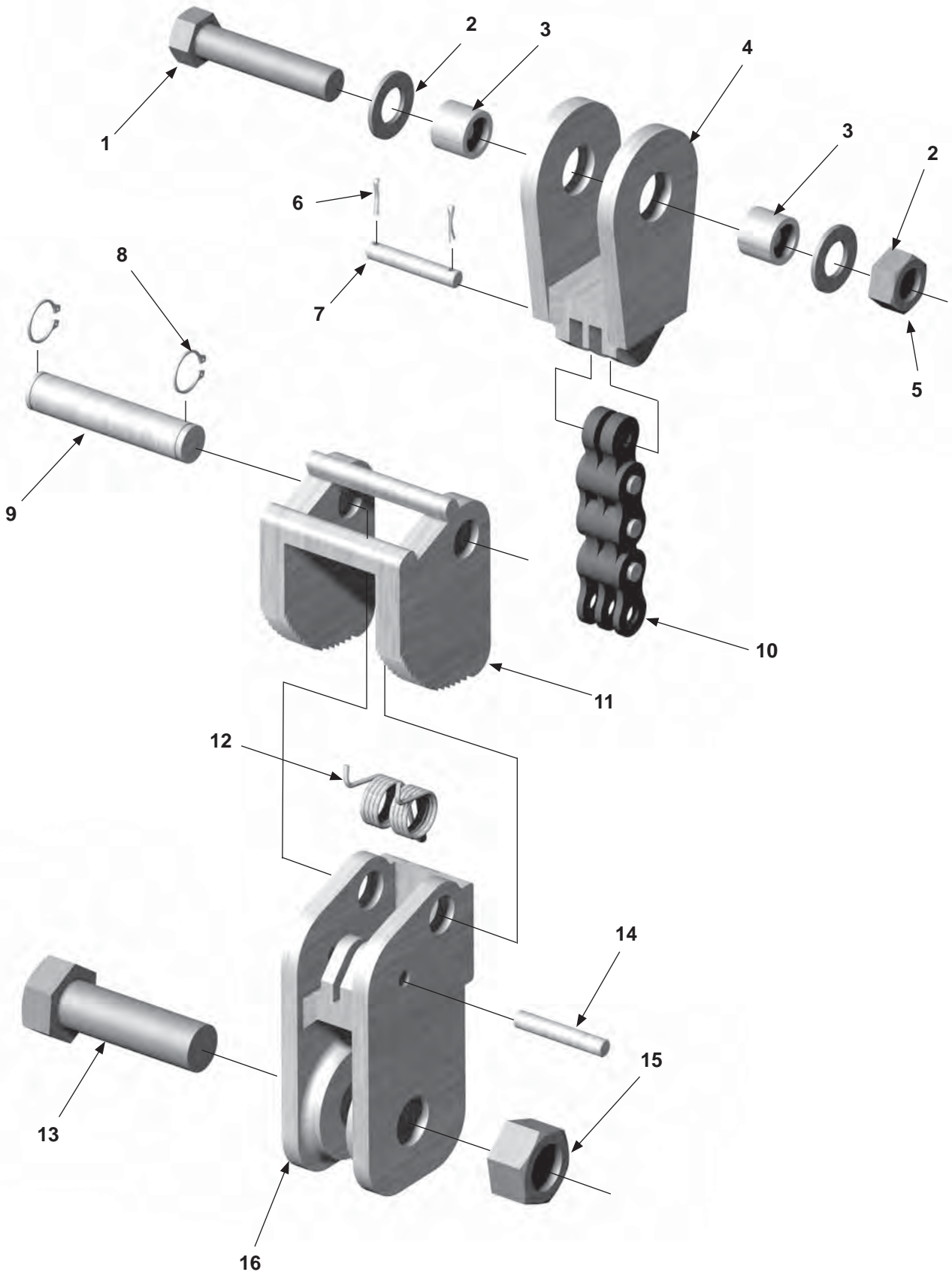

MAXON[®]

11921 Slauson Ave. Santa Fe Springs, CA. 90670 (800) 227-4116 FAX (888) 771-7713

ITEM	QTY.		PART NO.	DESCRIPTION
	RC-2, 3	RC-4, 5, 6		
REF	2		226969	EMERGENCY BRAKE
1	1	N/A	227317	HEX BOLT, 7/16"-20 X 2" LG, GRADE 8.
2	2		030585	FLAT WASHER, 7/16"
3	2		227315	ROUND TUBE, 5/8" O.D. X 1/2" LG.
4	1		226984	BRACKET
5	1	N/A	227316	HEX NUT, 7/16"-20 (ELASTIC STOP NUT)
6	2		226855	COTTER PIN
7	1		226982	PIN, LEAF CHAIN/BRACKET
8	2		227008	RETAINING RING
9	1		226979	SHAFT (CAM PIVOT)
10	1		226981-01	LEAF CHAIN
11	1		226975	SNAIL CAM
12	1		226980	TORSION SPRING
13	1	2	030064	HEX BOLT, 5/8"-18 X 2" LG, GRADE 5
14	1		226978	PIN, ANCHOR PLATE/LEAF CHAIN
15	1	2	226940	HEX NUT, 5/8"-18 (ELASTIC STOP NUT)
16	1		226970	ANCHOR PLATE

PUMP ASSEMBLY (CAM PLATFORM CLOSER)

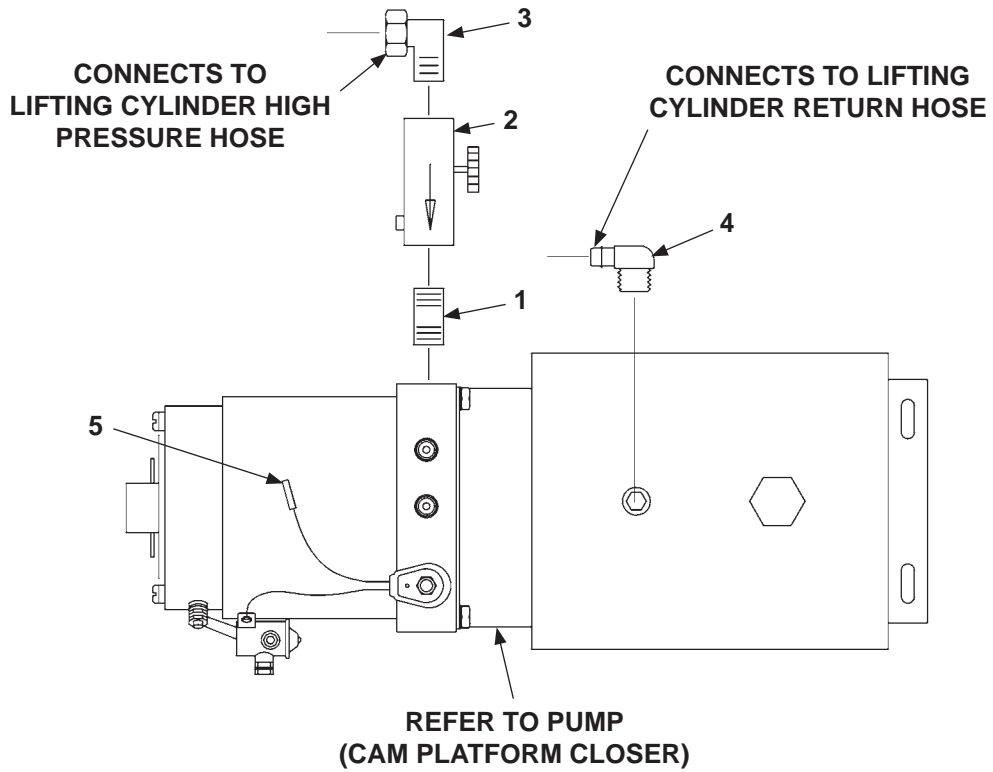

ITEM	QTY.	PART NO.	DESCRIPTION
REF	1	253342	PUMP ASSEMBLY (CAM CLOSER)
1	1	030304	PIPE NIPPLE, 3/8" X 2-1/2" LG.
2	1	253352	FLOW CONTROL VALVE, 1 WAY (ADJUSTABLE)
3	1	054036	ELBOW (90 DEG. WITH SWIVEL)
4	1	905270	ELBOW, BRASS (90 DEG.)
5	1	030491	CONNECTOR, BUTT-END, 14 AWG

MAXON[®]

11921 Slauson Ave. Santa Fe Springs, CA. 90670 (800) 227-4116 FAX (888) 771-7713

PUMP ASSEMBLY (HYDRAULIC PLATFORM CLOSER)

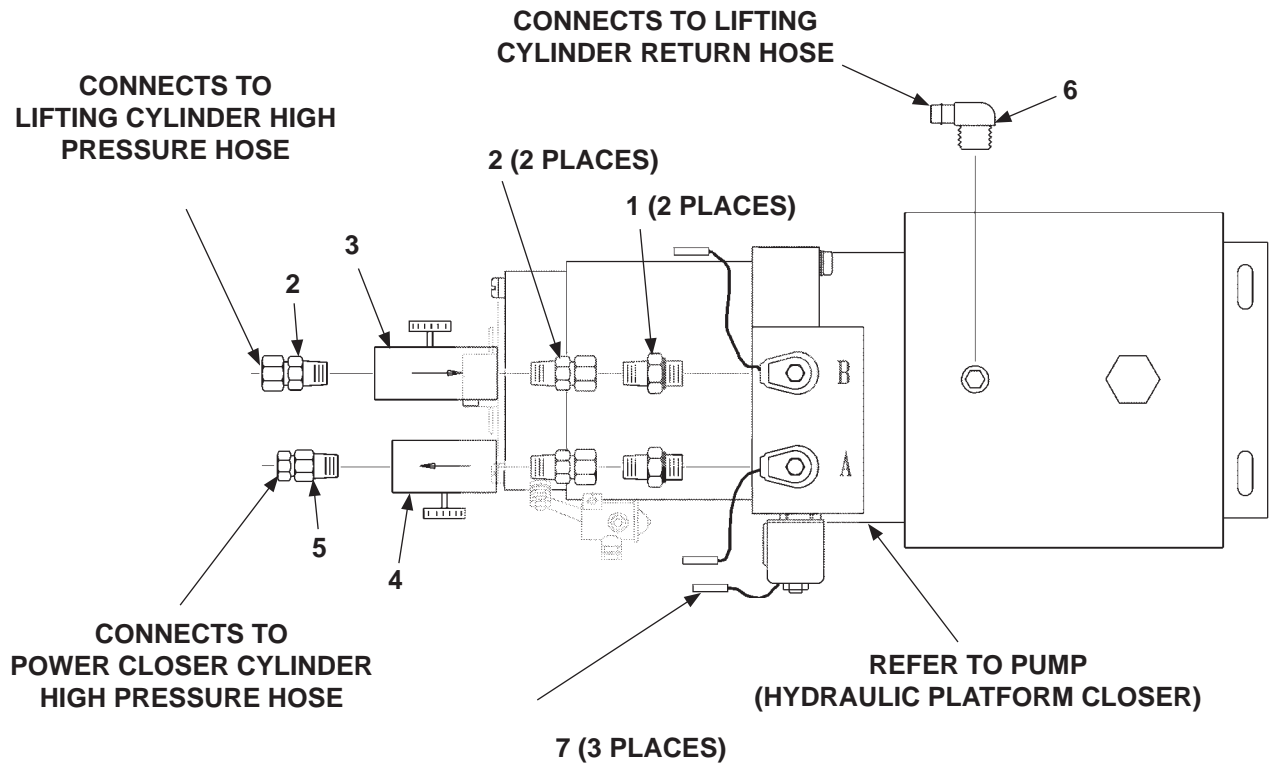

ITEM	QTY.	PART NO.	DESCRIPTION
REF	1	253802	PUMP ASSEMBLY (HYDRAULIC CLOSER)
1	2	253755	ADAPTER, O-RING, SAE#8 M - 3/8" NPTF M
2	3	228151	SWIVEL, STRAIGHT, 3/8" F - 3/8" M
3	1	253352	FLOW CONTROL VALVE, 1 WAY (ADJUSTABLE, 6.5 GPM)
4	1	260490	NEEDLE VALVE (FLOW CONTROL, ADJUSTABLE, 6.5 GPM)
5	1	251852	SWIVEL, STRAIGHT, 3/8" M - 1/4" F
6	1	905270	ELBOW, BRASS (90 DEG.)
7	3	030491	CONNECTOR, BUTT-END, 14 AWG

MAXON[®] 11921 Slauson Ave. Santa Fe Springs, CA. 90670 (800) 227-4116 FAX (888) 771-7713

PUMP (CAM PLATFORM CLOSER)

CAUTION

Do not over-tighten the terminal nuts on starter solenoid. For the load terminals, torque nuts to 40 lbs.-in. max. Torque the nuts on #10-32 control terminals 15-20 lbs.-in.

CAUTION

To prevent damage when installing 2-way valves, torque valve cartridge nut to 30 lbs.-in. max.

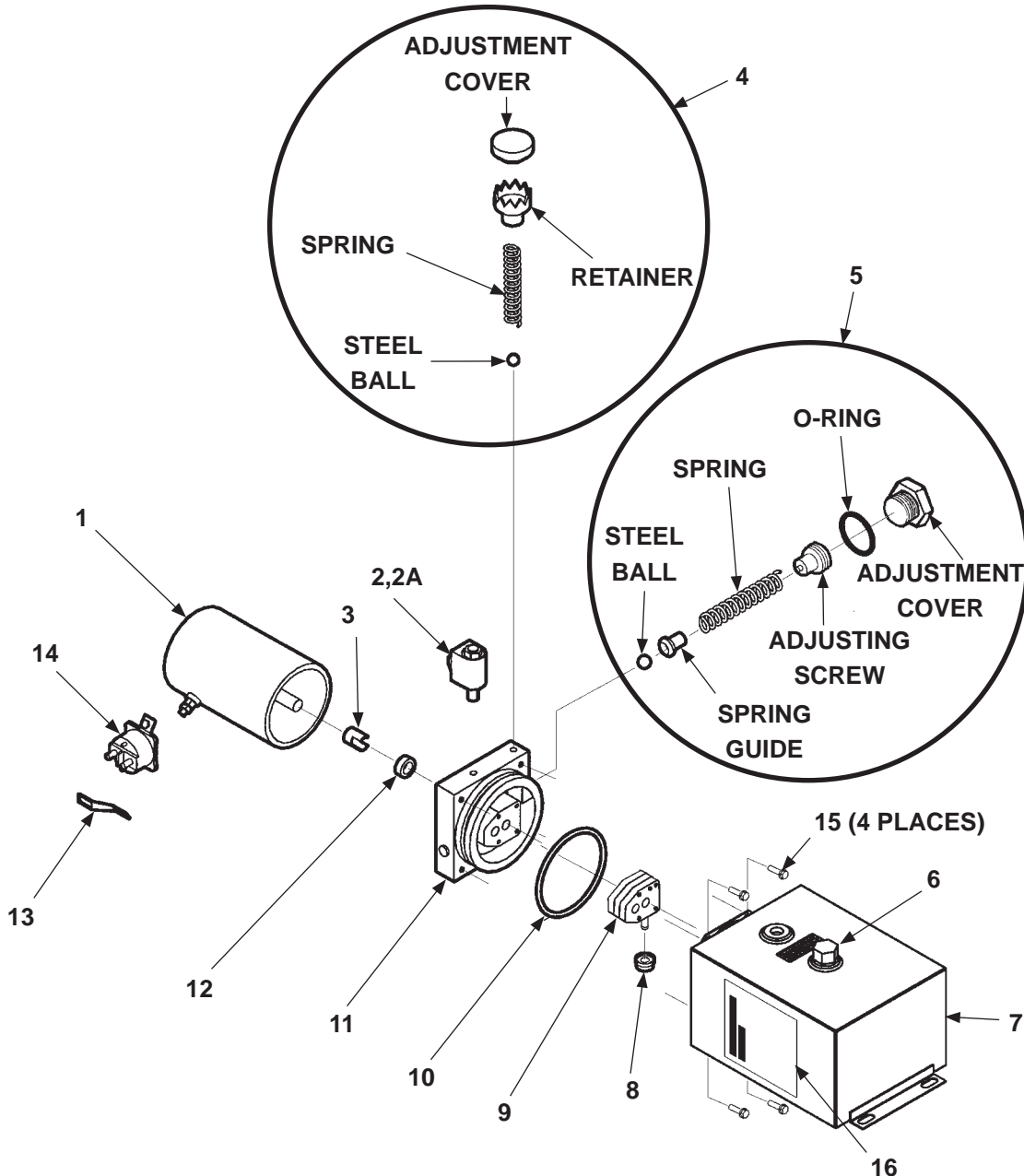

MAXON[®]

11921 Slauson Ave. Santa Fe Springs, CA. 90670 (800) 227-4116 FAX (888) 771-7713

ITEM	QTY.	PART NO.	DESCRIPTION
REF	1	253171	PUMP, HEAVY DUTY
1	1	250093	MOTOR, HEAVY DUTY 12 VOLTS DC
2	1	253353	VALVE, 2-WAY SOLENOID
2A	1	226594	O-RING KIT, 2-WAY VALVE (NOT SHOWN)
3	1	229200	COUPLING
4	1	251885	CHECK VALVE KIT
5	1	260229	RELIEF VALVE KIT
6	1	229193	FILLER/BREATHER CAP
7	1	260263	RESERVOIR, 2-1/2 GAL.
8	1	260250	FILTER
9	1	290003	3-PIECE GEAR PUMP
10	1	251884	O-RING
11	1	260252	DRIVE PLATE ASSEMBLY 5"
12	1	260261	OIL SEAL
13	1	262966	BUS BAR
14	1	262939	SOLENOID SWITCH
15	4	229202	CAP SCREW, HEX HEAD, WASHER HEAD
16	1	261740	LABEL, OIL LEVEL

MAXON[®] 11921 Slauson Ave. Santa Fe Springs, CA. 90670 (800) 227-4116 FAX (888) 771-7713

PUMP (HYDRAULIC PLATFORM CLOSER)

CAUTION

Do not over-tighten the terminal nuts on starter solenoid. For the load terminals, torque nuts to 40 lbs.-in. max. Torque the nuts on #10-32 control terminals 15-20 lbs.-in.

CAUTION

To prevent damage when installing 2-way valves, torque valve cartridge nut to 30 lbs.-in. max.

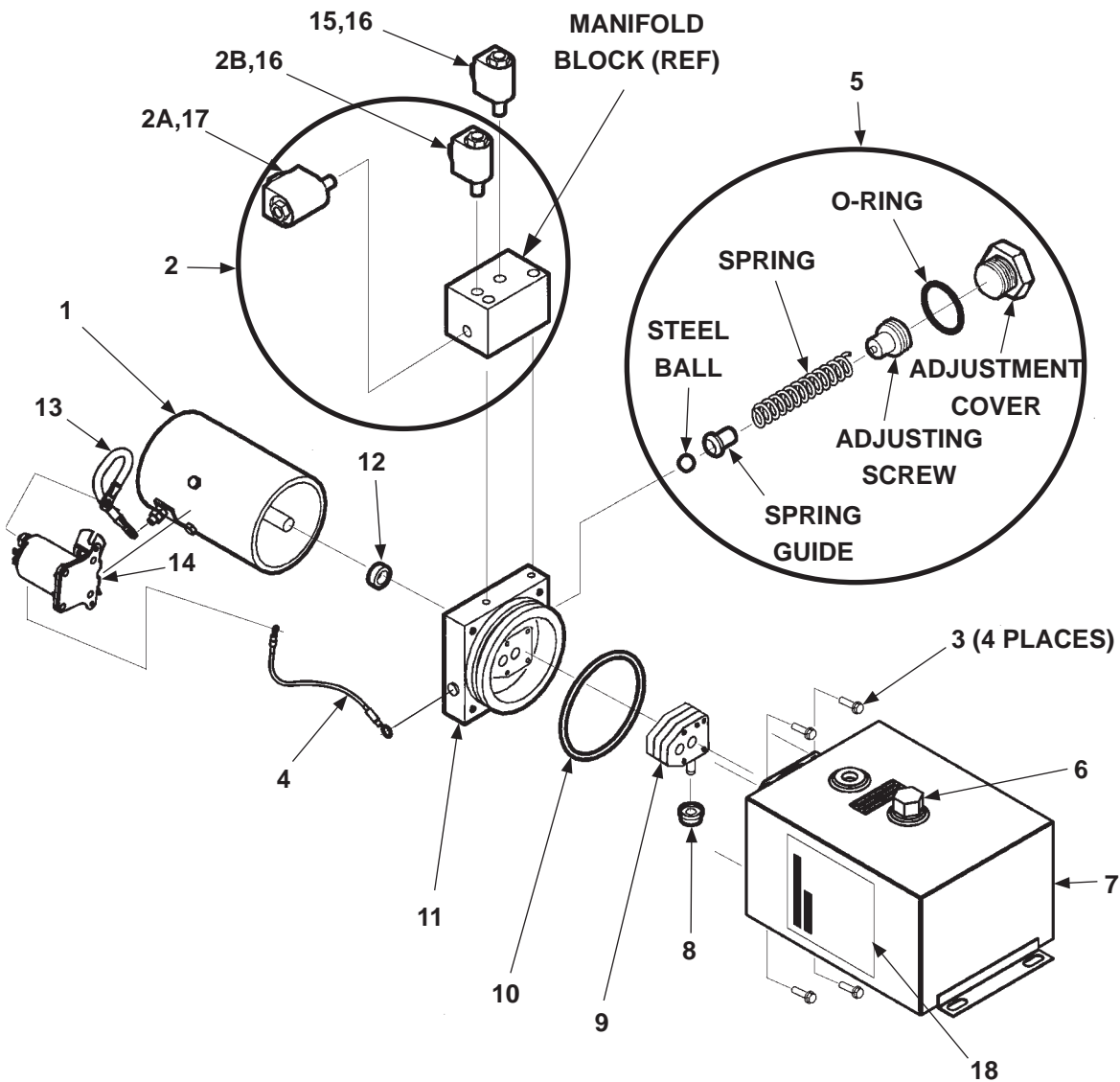
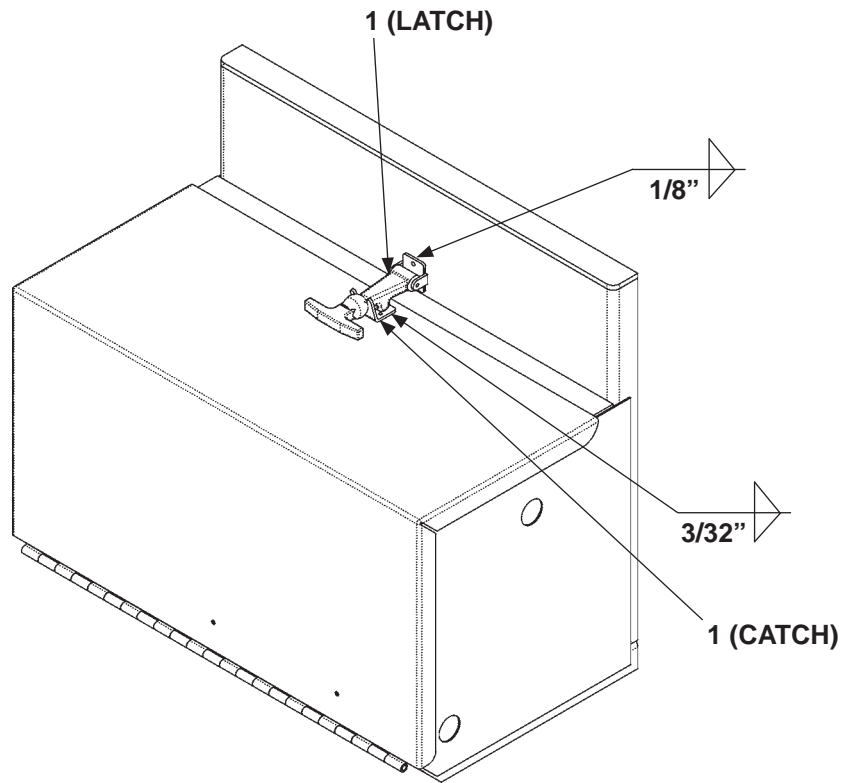

FIG. 64-1

ITEM	QTY.	PART NO.	DESCRIPTION
REF	1	262256	PUMP, EXTRA HEAVY DUTY
1	1	250093	MOTOR, HEAVY DUTY, 12 VDC
2	1	260275	MANIFOLD BLOCK ASSEMBLY
2A	1	260276	VALVE, 4-WAY SOLENOID
2B	1	253353	VALVE, 2-WAY SOLENOID
3	4	229202	CAP SCREW, HEX HEAD, WASHER HEAD
4	1	268026-01	WIRE ASSEMBLY, 18GA
5	1	260229	RELIEF VALVE KIT
6	1	229193	FILLER/BREATHER CAP
7	1	260263	RESERVOIR, 2.5 GAL.
8	1	260250	FILTER
9	1	290003	3-PIECE GEAR PUMP
10	1	251884	O-RING
11	1	REF. ONLY	DRIVE PLATE ASSY, 5"
12	1	260261	OIL SEAL
13	1	280404	CABLE ASSEMBLY
14	1	268030-01	SWITCH, SOLENOID (12 VDC)
15	1	253353	VALVE, 2-WAY SOLENOID (PART OF PUMP ASSY P/N 253802)
16	1	226594	O-RING KIT, 2-WAY VALVE (NOT SHOWN)
17	1	226595	O-RING KIT, 4-WAY VALVE (NOT SHOWN)
18	1	261740	LABEL, OIL LEVEL

MAXON® 11921 Slauson Ave. Santa Fe Springs, CA. 90670 (800) 227-4116 FAX (888) 771-7713

PUMP BOX



ITEM	QTY.	PART NO.	DESCRIPTION
REF	1	251048	PUMP BOX
1	1	215139	CATCH & FASTENER (LATCH)

PLATFORMS

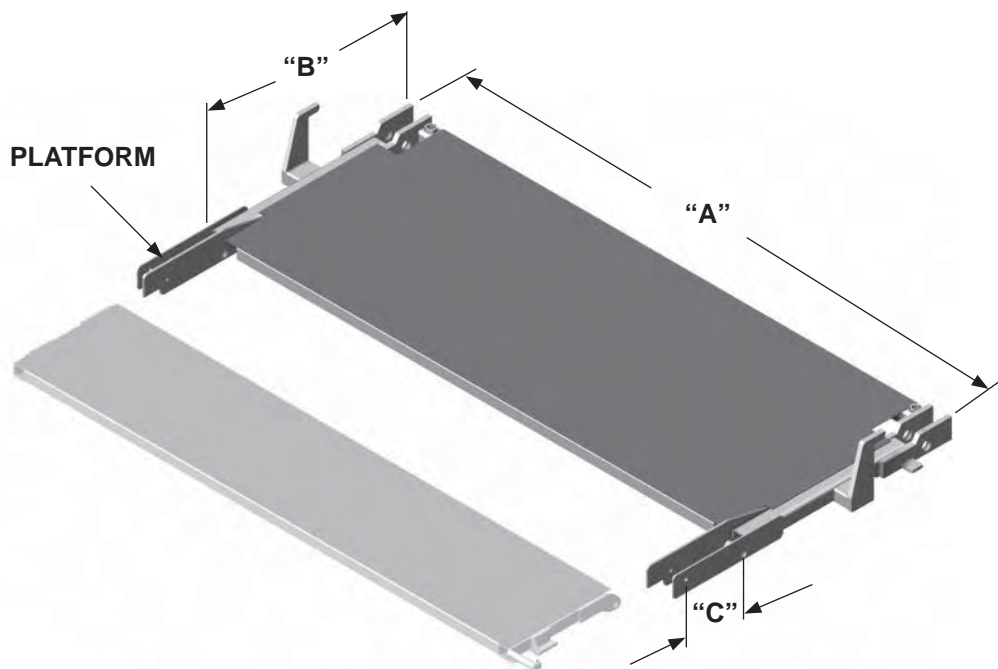

RC-2, RC-3, RC-4

RC-5, RC-6, RC-6K

MODEL	96" WIDE VEHICLE	96" WIDE VEHICLE (W/36" + F/S)	96" WIDE VEHICLE	96" WIDE VEHICLE (W/36" + F/S)
PART NO.	229330-01	229330-02	229330-03	229330-04
DIM. "A"	95-3/8"			
DIM. "B"	36"		42"	
DIM. "C"	10"	14"	10"	14"
MODEL	102" WIDE VEHICLE	102" WIDE VEHICLE (W/36" + F/S)	102" WIDE VEHICLE	102" WIDE VEHICLE (W/36" + F/S)
PART NO.	229330-05	229330-06	229330-07	229330-08
DIM. "A"	101-3/8"			
DIM. "B"	36"		42"	
DIM. "C"	10"	14"	10"	14"
MODEL	90" WIDE VEHICLE	90" WIDE VEHICLE (W/36" + F/S)	90" WIDE VEHICLE	90" WIDE VEHICLE (W/36" + F/S)
PART NO.	229330-09	229330-10	229330-11	229330-12
DIM. "A"	88-5/8"			
DIM. "B"	36"		42"	
DIM. "C"	10"	14"	10"	14"

MODEL	96" WIDE VEHICLE	96" WIDE VEHICLE (W/36" + F/S)	96" WIDE VEHICLE	96" WIDE VEHICLE (W/36" + F/S)
PART NO.	229331-01	229331-02	229331-03	229331-04
DIM. "A"	95-3/8"			
DIM. "B"	36"		42"	
DIM. "C"	10"	14"	10"	14"
MODEL	102" WIDE VEHICLE	102" WIDE VEHICLE (W/36" + F/S)	102" WIDE VEHICLE	102" WIDE VEHICLE (W/36" + F/S)
PART NO.	229331-05	229331-06	229331-07	229331-08
DIM. "A"	101-3/8"			
DIM. "B"	36"		42"	
DIM. "C"	10"	14"	10"	14"
MODEL	90" WIDE VEHICLE	90" WIDE VEHICLE (W/36" + F/S)	90" WIDE VEHICLE	90" WIDE VEHICLE (W/36" + F/S)
PART NO.	229331-09	229331-10	229331-11	229331-12
DIM. "A"	88-5/8"			
DIM. "B"	36"		42"	
DIM. "C"	10"	14"	10"	14"

MAXON[®] 11921 Slauson Ave. Santa Fe Springs, CA. 90670 (800) 227-4116 FAX (888) 771-7713

FLIPOVERS

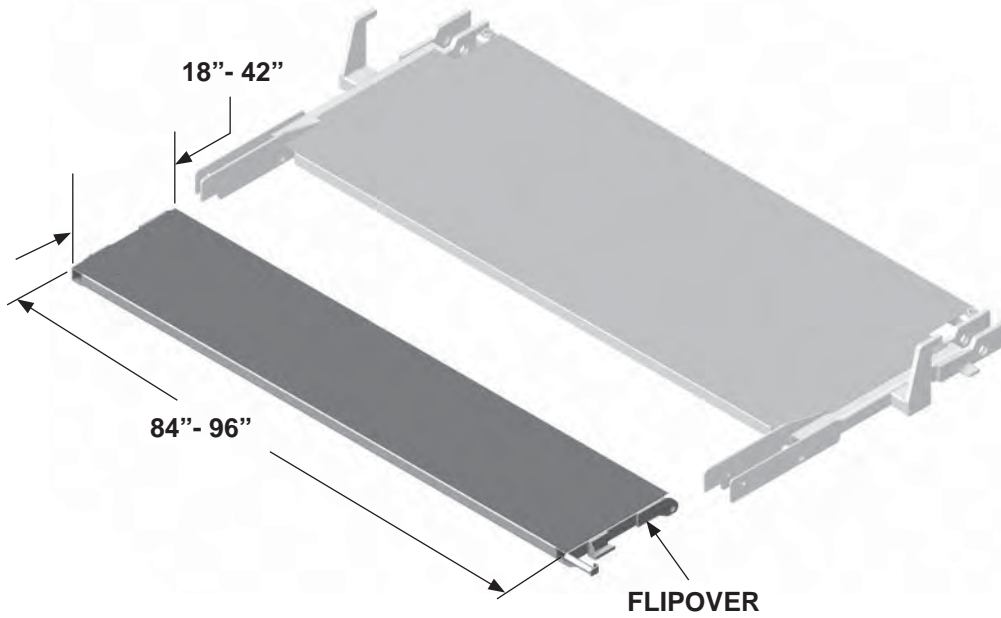

RC-2, RC-3, RC-4

96" WIDE VEHICLE		102" WIDE VEHICLE		90" WIDE VEHICLE	
FLIPOVER SIZE	PART NO.	FLIPOVER SIZE	PART NO.	FLIPOVER SIZE	PART NO.
90" x 18"	229334-01	96" x 18"	229334-06	84" x 18"	229334-11
90" x 24"	229334-02	96" x 24"	229334-07	84" x 24"	229334-12
90" x 30"	229334-03	96" x 30"	229334-08	84" x 30"	229334-13
90" x 36"	229334-04	96" x 36"	229334-09	84" x 36"	229334-14
90" x 42"	229334-05	96" x 42"	229334-10	84" x 42"	229334-15

RC-5, RC-6, RC-6K

96" WIDE VEHICLE		102" WIDE VEHICLE		90" WIDE VEHICLE	
FLIPOVER SIZE	PART NO.	FLIPOVER SIZE	PART NO.	FLIPOVER SIZE	PART NO.
90" x 18"	229335-01	96" x 18"	229335-06	84" x 18"	229335-11
90" x 24"	229335-02	96" x 24"	229335-07	84" x 24"	229335-12
90" x 30"	229335-03	96" x 30"	229335-08	84" x 30"	229335-13
90" x 36"	229335-04	96" x 36"	229335-09	84" x 36"	229335-14
90" x 42"	229335-05	96" x 42"	229335-10	84" x 42"	229335-15

ONE-PIECE PLATFORMS (CAM TYPE CLOSER)

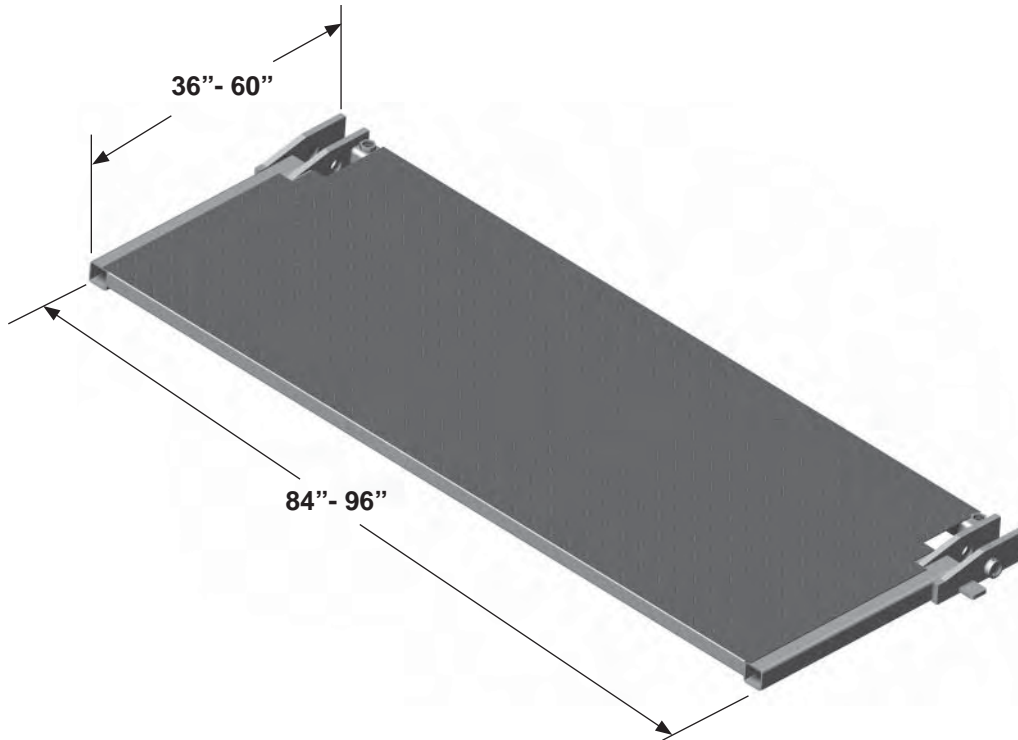

96" WIDE VEHICLE		102" WIDE VEHICLE		90" WIDE VEHICLE	
PLATFORM SIZE	PART NO.	PLATFORM SIZE	PART NO.	PLATFORM SIZE	PART NO.
90" x 36"	229336-01	96" x 36"	229336-05	84" x 36"	229336-09
90" x 42"	229336-02	96" x 42"	229336-06	84" x 42"	229336-10
90" x 48"	229336-03	96" x 48"	229336-07	84" x 48"	229336-11
90" x 60"	229336-04	96" x 60"	229336-08	84" x 60"	229336-12

MAXON[®] 11921 Slauson Ave. Santa Fe Springs, CA. 90670 (800) 227-4116 FAX (888) 771-7713

RC/RCT HYDRAULIC CLOSER COMPONENTS

NOTE: Parts shown on this page are found only on RC Liftgates with the hydraulic platform closer.

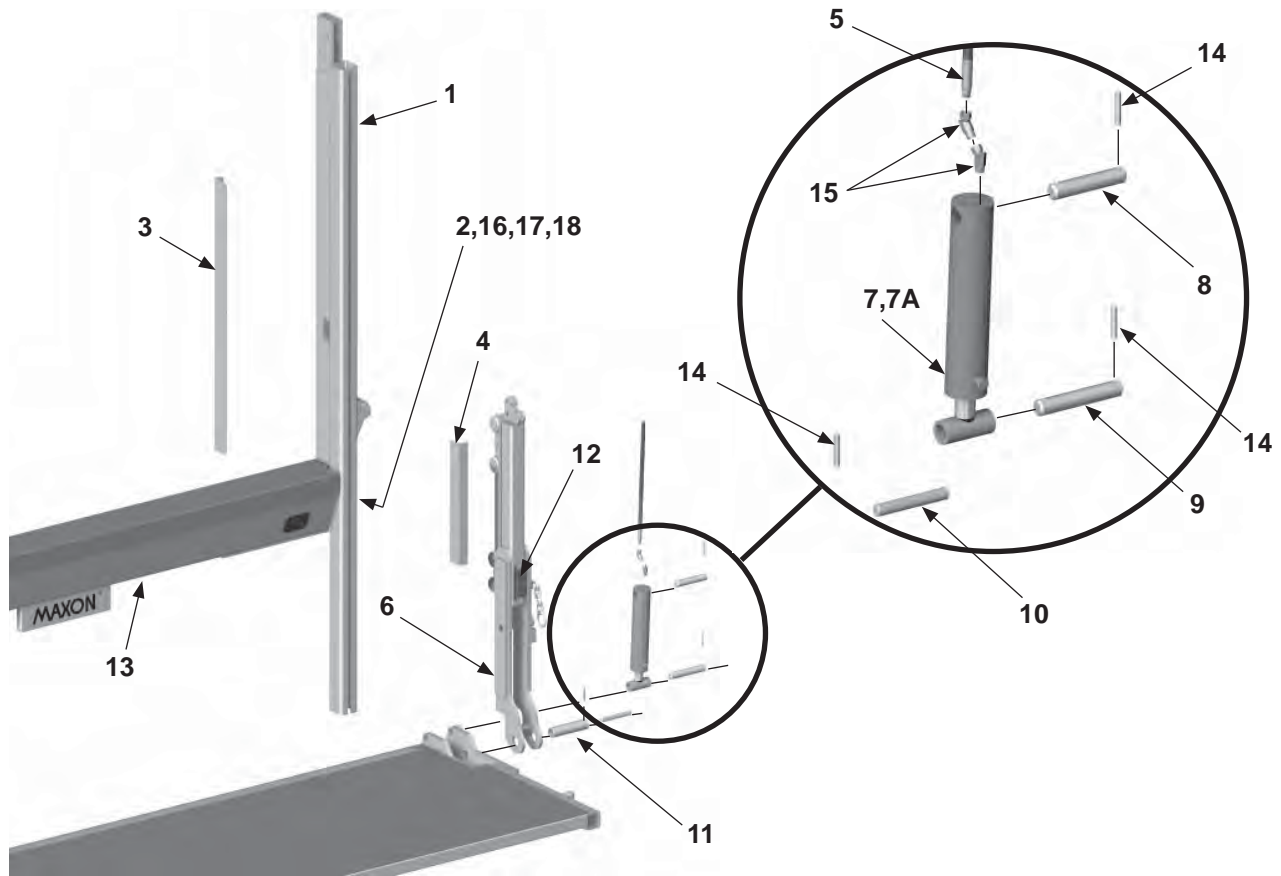

MAXON[®]

11921 Slauson Ave. Santa Fe Springs, CA. 90670 (800) 227-4116 FAX (888) 771-7713

ITEM	QTY.	PART NO.	DESCRIPTION
1	1	250912-01	MAIN FRAME COLUMN ASSEMBLY 96" WIDE (RC-2,RC-3)
		250912-06	MAIN FRAME COLUMN ASSEMBLY 102" WIDE (RC-2,RC-3)
		250914-01	MAIN FRAME COLUMN ASSEMBLY 96" WIDE (RC-4)
		250914-05	MAIN FRAME COLUMN ASSEMBLY 102" WIDE (RC-4)
		250908-01	MAIN FRAME COLUMN ASSEMBLY 96" WIDE (RC-5,RC-6)
		250908-05	MAIN FRAME COLUMN ASSEMBLY 102" WIDE (RC-5,RC-6)
2	1	253038	CHANNEL REMOTE CONTROL
3	1	227369	GUIDE, HOSE, MAIN FRAME
4	1	227370-01	GUIDE, HOSE, RUNNER (RC-2,RC-3)
		227370-02	GUIDE, HOSE, RUNNER (RC-4)
		227370-03	GUIDE, HOSE, RUNNER RC-5,RC-6)
5	1	800235-32	HOSE ASSEMBLY, 120" LONG
6	1	227334	RUNNER ASSEMBLY, RIGHT SIDE (RC-2,RC-3)
		227339	RUNNER ASSEMBLY, RIGHT SIDE (RC-4)
		227342	RUNNER ASSEMBLY, RIGHT SIDE (RC-5,RC-6)
7	1	222214	CYLINDER, 2" DIA. X 8" STROKE
7A	1	226568	SEAL KIT, HYDRAULIC CYLINDER, 2 X 8
8	1	073505	PIN, CYLINDER, UPPER, 5-1/4" LONG
9	2	070165	PIN, CYLINDER, LOWER, 6" LONG
10	1	221905-01	PIN, 5-1/8" LONG
11	1	222328	PIN, HINGE, 6" LONG
12	1	227664	RUBBER BUMPER
13	1	226201	COVER, MAIN FRAME 96" WIDE (RC-2,RC-3, RC-4)
		226200	COVER, MAIN FRAME 102" WIDE (RC-2,RC-3, RC-4)
		226458	COVER, MAIN FRAME 96" WIDE (RC-5,RC-6)
		226460	COVER, MAIN FRAME 102" WIDE (RC-5,RC-6)
14	5	221416	ROLL PIN, 3/8" X 2" LONG
15	2	227381	SWIVEL ELBOW, 45 DEG, 1/4" F X 1/4" M
16	1	250878	SWITCH MOUNTING PLATE
17	1	250994	DECAL P/F CLOSER
18	2	252427	ELECTRICAL SWITCH & HARNESS

TROUBLESHOOTING

CAM PLATFORM CLOSER

ERROR	CAUSE	REMEDY
PLATFORM WILL NOT RISE OR REACH FLOOR OF VEHICLE	1. BATTERY FLAT	RECHARGE BATTERY
	2. (TRACTOR/TRAILER VEHICLE ONLY) ELECTRICAL COUPLING TO TRACTOR NOT CONNECTED	CONNECT COUPLING
	3. INSUFFICIENT OIL IN THE PUMP RESERVOIR	FILL RESERVOIR (SEE DECAL ON PUMP)
	4. WIRE ROPE INCORRECTLY ADJUSTED	ADJUST WIRE ROPE
PLATFORM WILL NOT LOWER	1. BATTERY FLAT (VOLTAGE AT SOLENOID LOW)	RECHARGE BATTERY
	2. (TRACTOR/TRAILER VEHICLES ONLY) ELECTRICAL COUPLING TO TRACTOR NOT CONNECTED	CONNECT COUPLING
	3. EMERGENCY BRAKE LOCK-UP	RELEASE EMERGENCY BRAKE
PLATFORM DOES NOT RISE SMOOTHLY	1. TOO MUCH PUMP PRESSURE	CHECK PRESSURE
	2. INSUFFICIENT OIL IN THE PUMP RESERVOIR	FILL RESERVOIR
	3. AIR LOCK IN HYDRAULIC SYSTEM	OPERATE RAISE CONTROL ON THE SWITCH AT TOP OF PLATFORM STROKE FOR A FEW SECONDS. REPEAT TWO MORE TIMES, PAUSING BETWEEN OPERATIONS FOR ONE MINUTE WITH PLATFORM ON GROUND
	4. UNDUE MECHANICAL WEAR OR LACK OF LUBRICATION IN LIFTGATE	LUBRICATE OR REPLACE WORN PARTS
PLATFORM CREEPS DOWN UNDER NO LOAD CONDITION	1. HYDRAULIC LEAK	OPERATE RAISE CONTROL ON THE SWITCH AT TOP OF PLATFORM STROKE FOR A FEW SECONDS
	2. CYLINDER SEAL FAILING	REPLACE CYLINDER SEALS
	3. DIRT UNDER VALVE IN HYDRAULIC PUMP	CLEAN THE VALVE
PLATFORM WILL ONLY DESCEND SLOWLY	1. FLOW CONTROL VALVE ADJUSTMENT	ADJUST FLOW CONTROL VALVE
	2. INSUFFICIENT MAINTENANCE AND LUBRICATION	REVIEW MAINTENANCE AND LUBRICATION PROCEDURE
	3. UNDUE WEAR OF MECHANICAL COMPONENTS	REVIEW MAINTENANCE AND LUBRICATION PROCEDURE
	4. DIRT IN THE VALVE	CLEAN THE VALVE

MAXON[®]

11921 Slauson Ave. Santa Fe Springs, CA. 90670 (800) 227-4116 FAX (888) 771-7713

ERROR	CAUSE	REMEDY
PLATFORM WILL ONLY DESCEND SLOWLY (CONT'D)	5. INCORRECT OIL IN SYSTEM	DO THE "CHANGING HYDRAULIC FLUID" PROCEDURE IN THIS MANUAL
	6. RESTRICTED HYDRAULIC LINE	CHECK HOSE FOR EXTERNAL DAMAGE OR "PINCHING"
CANNOT ENGAGE PLATFORM RETENTION CHAIN	PLATFORM DOES NOT CLOSE ENOUGH TO ALLOW RETENTION CHAIN TO ENGAGE	DO THE "CAM FOLLOWER ADJUSTMENT" IN THIS MANUAL
PLATFORM TILTED	1. INCORRECT WIRE ROPE ADJUSTMENT	ADJUST WIRE ROPE
	2. WIRE ROPE SUPPORTING LOW SIDE OF PLATFORM DISLODGED FROM ITS NORMAL LAY	CHECK THAT WIRE ROPE IS CORRECTLY SEATED IN THE GROOVES OF THE SHEAVES OVER WHICH THE WIRE ROPE PASSES
	3. WIRE ROPES, RUNNERS OR PLATFORM OBSTRUCTED	CHECK FREEDOM OF ALL MOVING PARTS ASSOCIATED WITH WIRE ROPE SYSTEM
UNIT WILL NOT LIFT RATED LOAD	1. RELIEF VALVE SETTING TOO LOW	ADJUST RELIEF VALVE SETTING
	2. HYDRAULIC PUMP WORN	CHANGE WORN PARTS OR PUMP ASSEMBLY. SEE PUMP BREAKDOWN ILLUSTRATIONS
PLATFORM NOT LEVEL	1. 2 PC PLATFORM CHAINS TOO LONG	SHORTEN CHAINS
PUMP WILL NOT OPERATE	1. BATTERY IS UNDER-CHARGED	RECHARGE BATTERY
	2. (TRACTOR/TRAILER VEHICLE ONLY) ELECTRICAL COUPLING TO TRAILER NOT CONNECTED	CONNECT COUPLING
	3. ELECTRICAL WIRING TO PUMP BROKEN OR CORRODED	CHECK WIRING TO PUMP
	4. REMOTE CONTROL SWITCH WIRING BROKEN	CHECK WIRING TO REMOTE CONTROL SWITCHES
	5. SOLENOID SWITCH ON PUMP FAULTY	CHECK SOLENOID SWITCH